

MODELS:

**System**

7 kW - DSNR07B1

9 kW - DSNR09B1

11 kW - DSNR11B1

13 kW - DSNR13B1

15 kW - DSNR15B1

18 kW - DSNR18B1

**Indoor**

DINLR07B1

DINLR09B1

DINLR011B1

DINLR13B1

DINLR15B1

DINLR18B1

**Outdoor**

DONSR07B1

DONSR09B1

DONSR11B1

DONSR13B1

DONSR15B1

DONSR18B1

REFRIGERANT  
**R32**

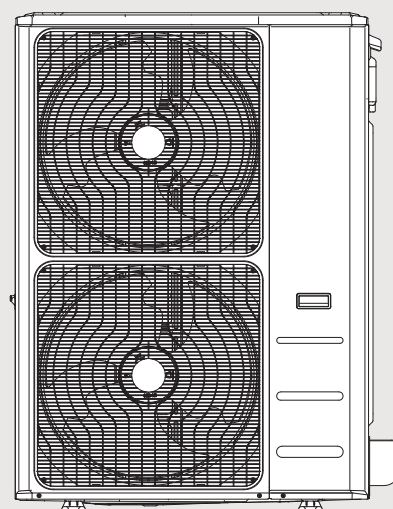
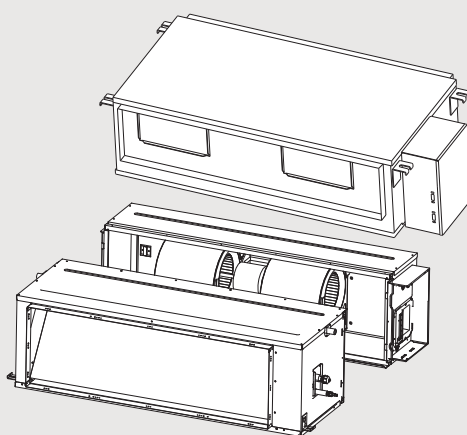
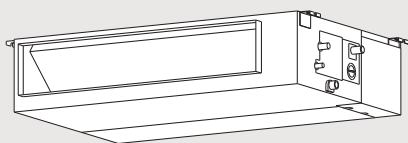

# Pro Series Ducted Central Heating & Cooling Systems

## Installation guide

# Rinnai

---

# Important

---

This appliance must be installed in accordance with:

- Manufacturer's installation instructions
- Current AS/NZS 3000, AS/NZS 3500 National Plumbing & Drainage, AS/NZS 5141, AS/NZS 5419, AS/NZS 1677, AS/NZS 60335.2.40, and G12/AS1
- HB276 - A Guide to good practice for energy efficient installation

This appliance must be installed, maintained and removed only by an authorised person.

The system is not suitable for commercial applications requiring a controlled atmosphere, for example server rooms, food storage etc.

For continued safety of this appliance it must be installed and maintained in accordance with the manufacturer's instructions.

## **Warning**

Improper installation, adjustment, alteration, service and maintenance can cause property damage, personal injury or loss of life.

For more information about buying, using, and servicing of Rinnai appliances call: 0800 RINNAI (0800 746 624).

Rinnai New Zealand Limited  
105 Pavilion Drive, Mangere, Auckland  
PO Box 53177, Auckland Airport, Auckland 2150

Phone: (09) 257-3800  
Email: [info@rinnai.co.nz](mailto:info@rinnai.co.nz)  
Web: [rinnai.co.nz](http://rinnai.co.nz)  
[youtube.com/rinnainz](https://www.youtube.com/rinnainz)  
[facebook.com/rinnainz](https://www.facebook.com/rinnainz)

---

# Contents

---

Safety and important information.....	4
Specification summary .....	6
System components .....	7
Installation summary.....	8
Indoor unit installation.....	9
Indoor unit installation - hanging bolts .....	11
Indoor unit installation - air inlet direction .....	12
Indoor unit installation - drain pipe.....	13
Outdoor unit installation - location .....	15
Outdoor unit installation - mounting dimensions... ..	16
Outdoor unit drain joint and anchoring .....	17
Refrigerant piping connection.....	18
Wiring and controllers.....	21
Power and communication connections .....	22
Outdoor unit wiring .....	24
Indoor unit wiring .....	26
Pressure and leak test.....	27
Evacuation.....	28
Test run.....	29
Appendix 1: Fan performance charts .....	31
Appendix 2: Error code summary .....	34
Appendix 3:	
18 kW indoor unit - separating and reconnecting ..	35



Images in this guide are for illustration purposes. The system purchased may be slightly different in design.

# Safety messages / important information



This appliance is heavy, use two people or a mechanical lifting device. Improper lifting may result in serious injury.

For safety and warranty, appliances that are damaged **MUST NOT** be installed or operated under any circumstances.

## Electrical warnings



**DO NOT** modify the electrical wiring of this appliance. If the control power wiring is damaged or deteriorated then it must be replaced by an authorised person. Failure to do so may result in electric shock, fire, serious injury, or product failure.

All electrical connections **MUST** be made according to the wiring diagrams located on the panels of the indoor and outdoor units.

The PCB is designed with a fuse to provide overcurrent protection. The specifications of the fuse are printed on the PCB. For units using R32 refrigerant, only a blast-proof ceramic fuse can be used.

Power voltage should be within 90-110% of rated voltage. Insufficient power supply can cause a malfunction, electrical shock, or fire.

Only connect the unit to an individual branch circuit outlet. **DO NOT** connect another appliance to that outlet.

## Electrical wires

This a Class 1 electrical appliance. Make sure the live wire, neutral wire, and earth wire in the power socket are properly connected. Inadequate or incorrect electrical connections may cause fire or electric shock.

The yellow-green wire in the air conditioner is the earthing wire which cannot be used for any other purpose. Improper earthing may cause electric shock. The unit must be earthed in accordance with local regulations.

Every wire must be firmly connected. Loose wiring can cause the terminal to overheat, resulting in a product malfunction and possible fire.

Do not let live wires touch or rest against refrigerant tubing, the compressor, or any moving parts within the unit.

## Circuit breaker

The circuit break must have the functions of magnetic tripping and heat tripping to prevent short circuiting and/or overload. Use a standard circuit breaker and fuse conforming with the rating of the appliance.

## Fixed wiring

If connecting power to fixed wiring<sup>1</sup>:

- A surge protector and mains power switch should be installed.
- A switch or circuit breaker that disconnects all poles and has a contact separation of at least  $\frac{1}{8}$ " (3 mm) must be incorporated in the fixed wiring.

<sup>1</sup> Consult a qualified electrician as it must comply with AS/NZS 5601 and AS/NZS 3000 and other relevant local regulations.

## R32 refrigerant

This appliance uses R32 (difluoromethane) refrigerant, which is a flammable gas class A2L according to AS 5149.1 and MUST BE handled by a refrigerant mechanic with the appropriate refrigerant handling licence.



Warning risk of fire / flammable material. If the refrigerant is leaked, together with an ignition source, there is a possibility of ignition.

## Minimum room sizes

When flammable refrigerants are used the appliance shall be located in a well ventilated area where the room size corresponds to the room area as specified for operation, refer table below.

Please ensure that these minimum room sizes are adhered to for standard installations (up to 15 m pipe length). If larger refrigerant charges than standard are used the installer must consult AS/NZS 60335.2.40 to determine the safe minimum floor area for the installation. Minimum room sizes are calculated on the base charge provided with the outdoor unit.

Model	DONSR07B1	DONSR09B1	DONSR11B1	DONSR13B1	DONSR15B1	DONSR18B1
Standard charge (g)	1750	2600	2600	3600	3600	4000
Min. floor area (m <sup>2</sup> )	1.94	4.28	4.28	8.20	8.20	10.13

## Location and positioning

Installation must be in a position that can support the unit's weight. If the chosen location cannot support the weight of the unit, or the installation is not done properly, the unit may drop and cause serious injury or damage.

The installer must install drainage piping according to the installation instructions. Improper drainage may cause water damage to your home or property.

- Do not install the unit in location that may be exposed to combustible gas leaks. If combustible gas accumulates around the unit, it may cause a fire.
- Do not install the outdoor unit where noise may cause a nuisance, such as near bedrooms or neighbouring properties.
- Where possible do not install the outdoor unit where it will be exposed to sea wind and salt spray, this will significantly reduce the durability of the unit.

## Flexible demand (DRED - Demand Response Enabling Device)

Rinnai ducted R32 models are compatible with air conditioning demand response programs, which allow energy providers to manage peak demand periods by reducing the power consumption of the compressor. This can be enabled by purchasing a separate component.

Mode	Mode description
DR mode 1	Compressor off
DR mode 2	The air conditioner continues to cool or heat during demand response activation, but the total electrical energy (kWh) consumed by the air conditioner in a half hour period is not more than 50% of the total electrical energy that would be consumed in a half hour period during normal operation—under the same temperature and humidity conditions (and the same user settings).
DR mode 3	The air conditioner continues to cool or heat during demand response activation, but the total electrical energy (kWh) consumed by the air conditioner in a half hour period is not more than 75% of the total electrical energy that would be consumed in a half hour period during normal operation—under the same temperature and humidity conditions (and the same user settings).

For more information on the wired connection to the DR board refer to the supplementary information available online or contact Rinnai for further information.

# Specification summary

Rinnai R32 ducted system			7 kW	9 kW	11 kW	13 kW	15 kW	18 kW
<b>Nominal capacity</b>								
Power supply to outdoor unit		V-Ph-Hz	220-240 - 1-50					
Max. input power		W	3400	4600	4600	7000	7000	7000
Max. input current		A	16	21	21	31	31	31
Recommended circuit breaker size		A	20	25	25	32	32	32
Cooling	Rated capacity	kW	7.3	9.0	10.5	12.5	14	17
	Capacity range	kW	2.38-9.0	3.15-11.85	3.15-11.85	4.20-15.75	4.20-15.75	6.80-19.50
	Rated input power	kW	2.1	2.6	3.1	3.5	4.2	5.3
	Rated input current	A	9.8	14.5	14.2	18.2	18.2	22.5
	AEER	W/W	3.4	3.5	3.3	3.5	3.2	3.2
Heating	Rated capacity	kW	7.5	10.0	11.5	13.0	14.5	18.0
	Capacity range	kW	1.79-10.5	3.45-13.5	3.45-13.50	4.44-16.85	4.44-16.65	6.90-21.10
	Rated input power	kW	1.7	2.25	2.7	3.15	3.6	4.55
	Rated input current	A	7.9	12.8	12.8	16.3	16.3	19.5
	ACOP	W/W	4.3	4.4	4.0	4.1	4.0	3.9
<b>Indoor unit</b>								
Fan motor rated input		W	90	250	560	560	560	420
Fan motor rated current		A	1.6	2.5	2.5	3.0	3.0	3.0
Air flow @100 Pa (with filter)	High speed	L/s	480	625	810	1090	1090	1180
Min. air flow		L/s	140	190	190	250	250	410
Max. external static pressure		Pa	160	160	200	200	200	200
Noise level	Sound pressure @1.4 m (hi/med/lo)	dB(A)	38.5/35.5/32.5	45/42/39.5	39/37/34.5	46.5/43.5/40	46.5/43.5/40	53/49.5/45.3
Dimensions	Net (WxDxH)	mm	1100x774x249	1360x774x249	1200x625x380	1200x625x380	1200x625x380	1400x858x440
	Packaging (WxDxH)	mm	1305x805x315	1570x805x320	1485x675x450	1485x675x450	1485x675x450	1640x910x505
	Net/gross weight	kg	32/39	40/48	53/62	53/62	53/62	81/93
Duct connections	Supply air (WxH)	mm	926x175	1186x175	1000x253	1000x253	1000x253	1188x385
	Return air (WxH)	mm	1001x228	1261x228	1145x334	1145x334	1145x334	1188x385
Condensate drain pipe outer diam.		mm	Ø25					
Refrigerant piping	Liquid/gas connections	mm	9.5/15.9	9.5/15.9	9.5/15.9	9.5/15.9	9.5/15.9	9.5/19.0
Moisture removal		L/h	2	2.5	2.7	3.0	3.0	3.5
Controller		Type	Wired programmable controller (sold separately)					
Operating range		°C	Cooling 17~32, heating 0~30					
<b>Outdoor unit</b>								
Starting current		A	2.2	2.5	2.5	3.6	3.6	4
Compressor		Type	Twin rotary					
Sound pressure @1 m		dB(A)	60	60	62	60	60	60.5
Sound power level		dB(A)	65	68	68	70	70	72
Dimensions	Net (WxDxH)	mm	890x342x673	946x410x810	946x410x810	952x415x1333	952x415x1333	952x415x1333
	Packaging (WxDxH)*	mm	1030x438x790	1090x500x935	1090x500x935	1095x495x1490	1095x495x1490	1095x495x1470
	Net/gross weight*	kg	45/58	70/85	70/85	95/111	95/111	96/112
Refrigerant piping		Type	R32					
	Charged volume	kg	1.75	2.6	2.6	3.6	3.6	4.0
	Design pressure	MPa	4.3/1.7					
	Pre-charged length	m	15					
	Change adjustment (add or remove)	g/m	24					
	Liquid/gas connections	mm	9.5/15.9	9.5/15.9	9.5/15.9	9.5/15.9	9.5/15.9	9.5/19.0
	Max. pipe length	m	50	75	75	75	75	75
	Min. pipe length	m	3					
Max. vert. separation	m	25	30	30	30	30	30	
Ambient temp limits		°C	Cooling 0~50, heating -20~24					

\* Wooden pallet included

# System components

The ducted system comes in a number of boxes along with an accessory pack. The accessory pack is included with the indoor unit—DO NOT throw away as these parts are required for installation. Improper installation may result in water leakage, electrical shock and fire, or cause the equipment to fail. **Please note:** Wired controllers are sold separately.

The illustrations below are representative only.

Accessory pack contains:

1.	Soundproof / insulation x 2	9.	Copper nut x 2
2.	Display control	10.	Magnetic ring <sup>1</sup>
3.	Cord protection rubber ring x 2	11.	Magnetic ring <sup>2</sup>
4.	External drain joint	12.	Magnetic ring <sup>3</sup>
5.	Internal drain joint	13.	Cable ties x 8
6.	Outlet pipe sheath	14.	Fan coil condensate joiner
7.	Outlet pipe clasp x 2		
8.	Seal ring		

<sup>1</sup> Wrap electric wires S1 & S2 (P & Q & E) around the magnetic ring twice (some models)

<sup>2</sup> Hitch it on the connective cable between the indoor unit and outdoor unit after installation (some models)

<sup>3</sup> Twist the electric wires L & N around the magnetic ring to five circles

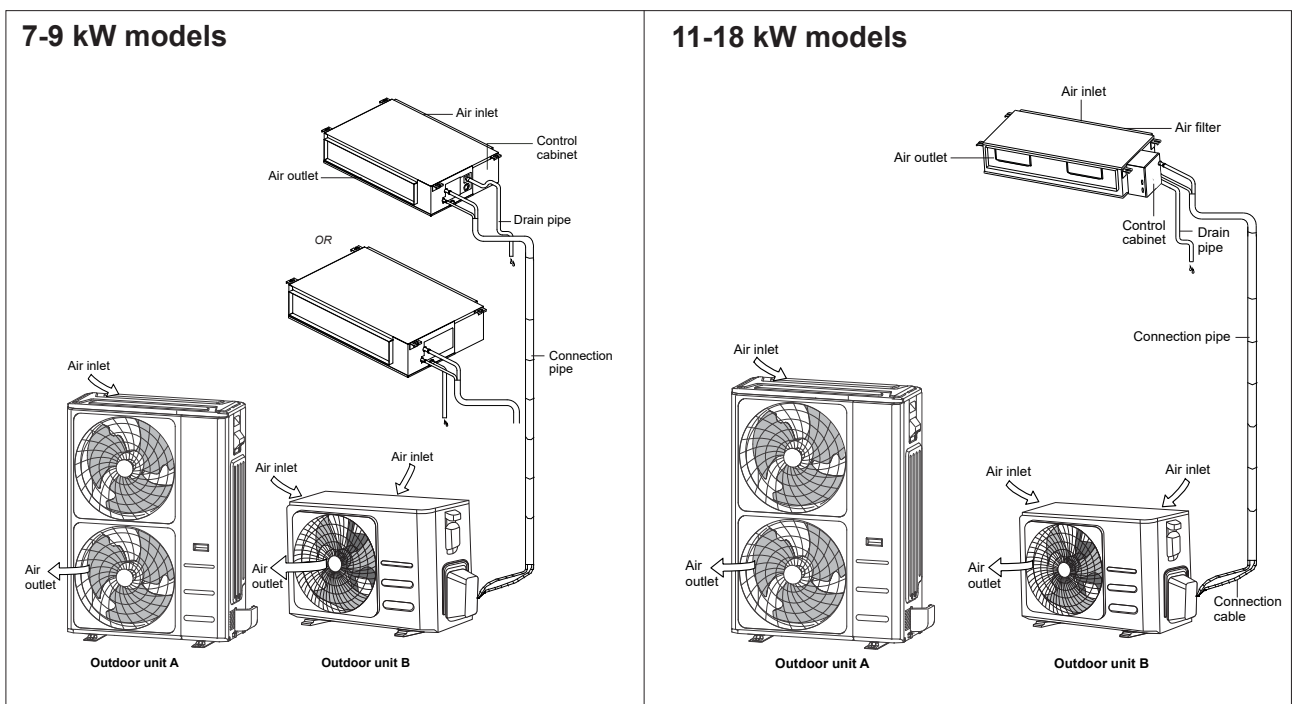
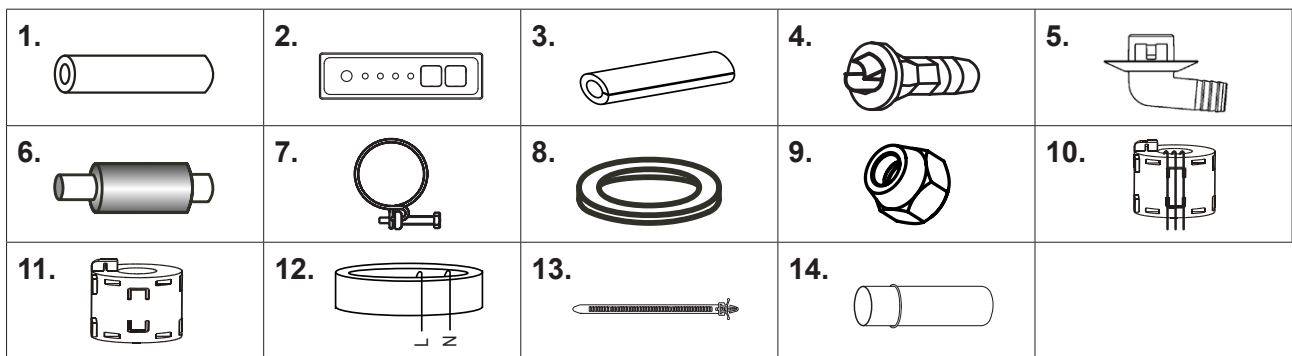

# Installation summary

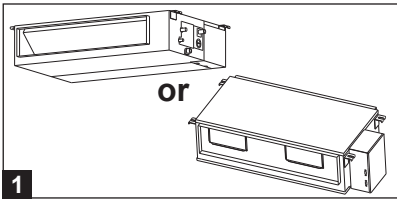

**1** Install the indoor unit.

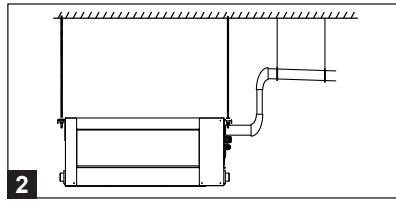

**2** Install the drain pipe.

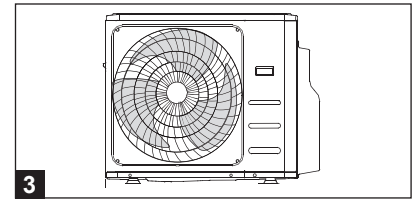

**3** Install the outdoor unit.

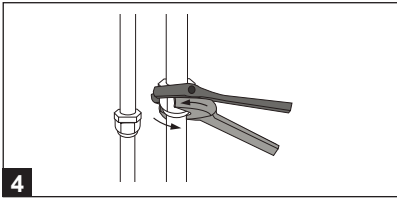

**4** Connect the refrigerant pipes.

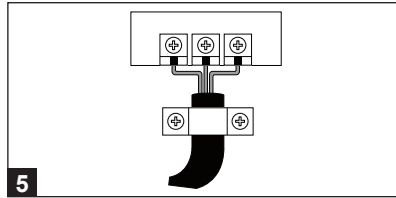

**5** Connect the wires.

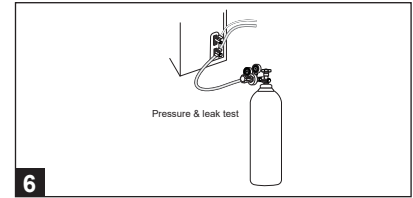

**6** Pressure test and leak test.

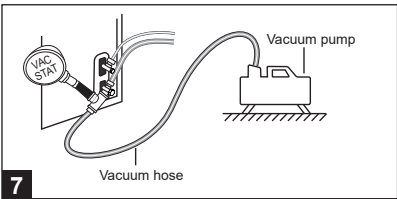

**7** Evacuate the system.

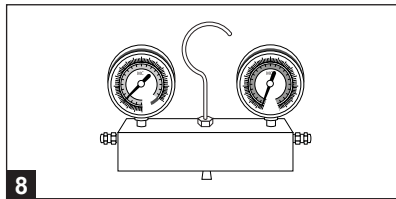

**8** Charge the system.

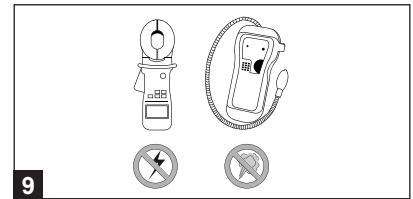

**9** Perform a test run.

# Indoor unit installation

Before installing the indoor unit, ensure the location is suitable:

- There needs to be enough room for installation, maintenance and service (refer diagram below), and for connecting the pipe and drain pipe.
- The unit is installed level and the structure can support the weight of the indoor unit.
- The air inlet and outlet are unobstructed.
- The airflow rates and heating / cooling capacity are suitable.
- There is no direct radiation from a heat source.

DO NOT install in the following locations:

- Beneath a deck or other outdoor area
- In enclosed spaces such as cabinets
- Areas where power fluctuations are frequent
- Kitchens that use natural gas or LPG
- Areas with strong electromagnetic waves
- Areas that store flammable materials or gas
- Rooms with high humidity, such as bathrooms or laundry rooms

## Maintenance and service access

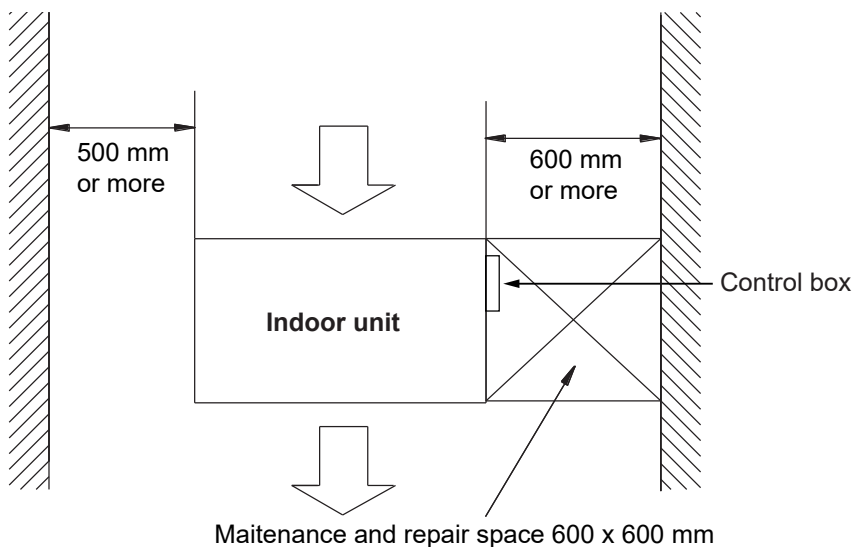

## Safety tray and drain

- Always install a safety drain tray (field supplied)
- The safety drain tray should be independently drained
- Terminate the safety drain tray in a position so as not to cause a nuisance, and where the homeowner can see if water is dripping.
- Instruct the owner to contact installer or Rinnai if the safety drain tray outlet drips water

## 7-9 kW models

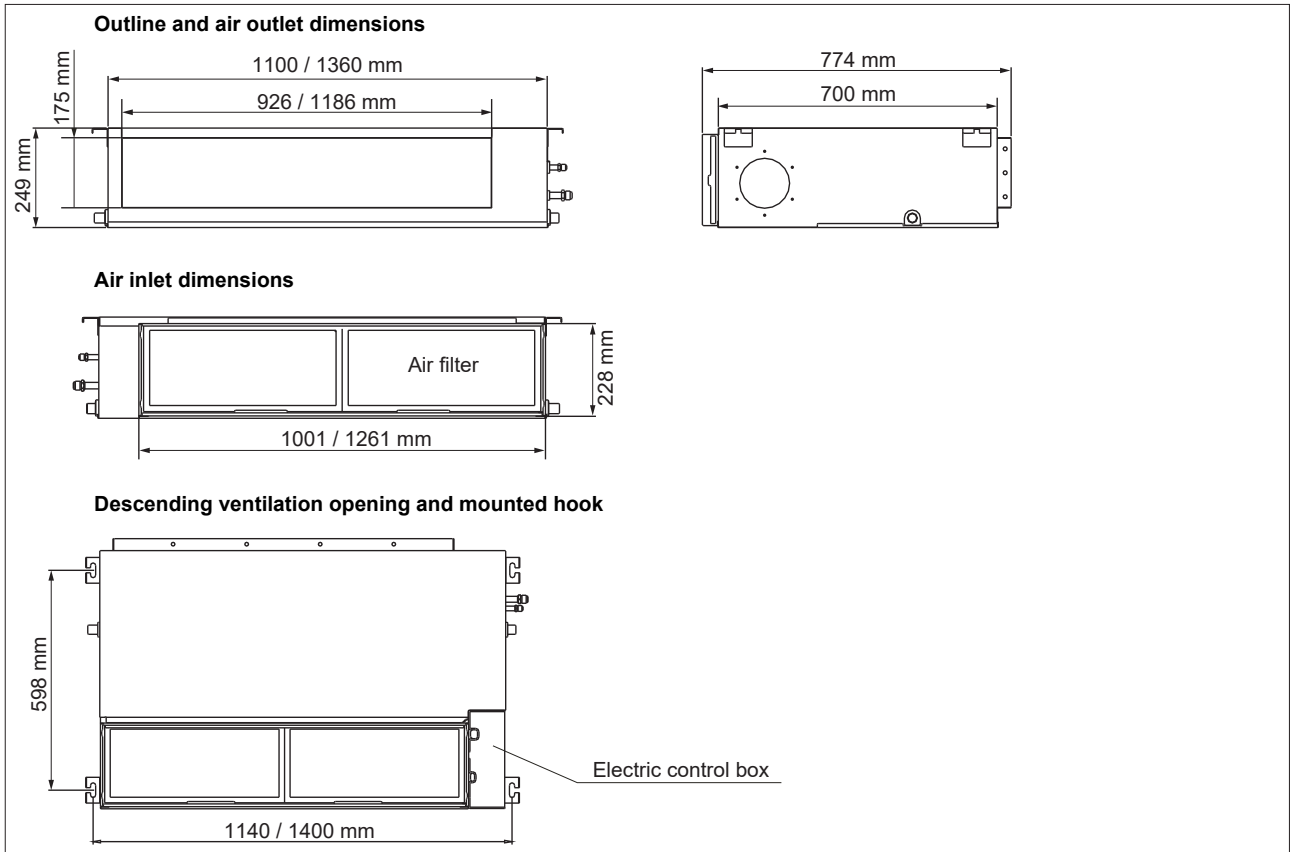

## 11-18 kW models

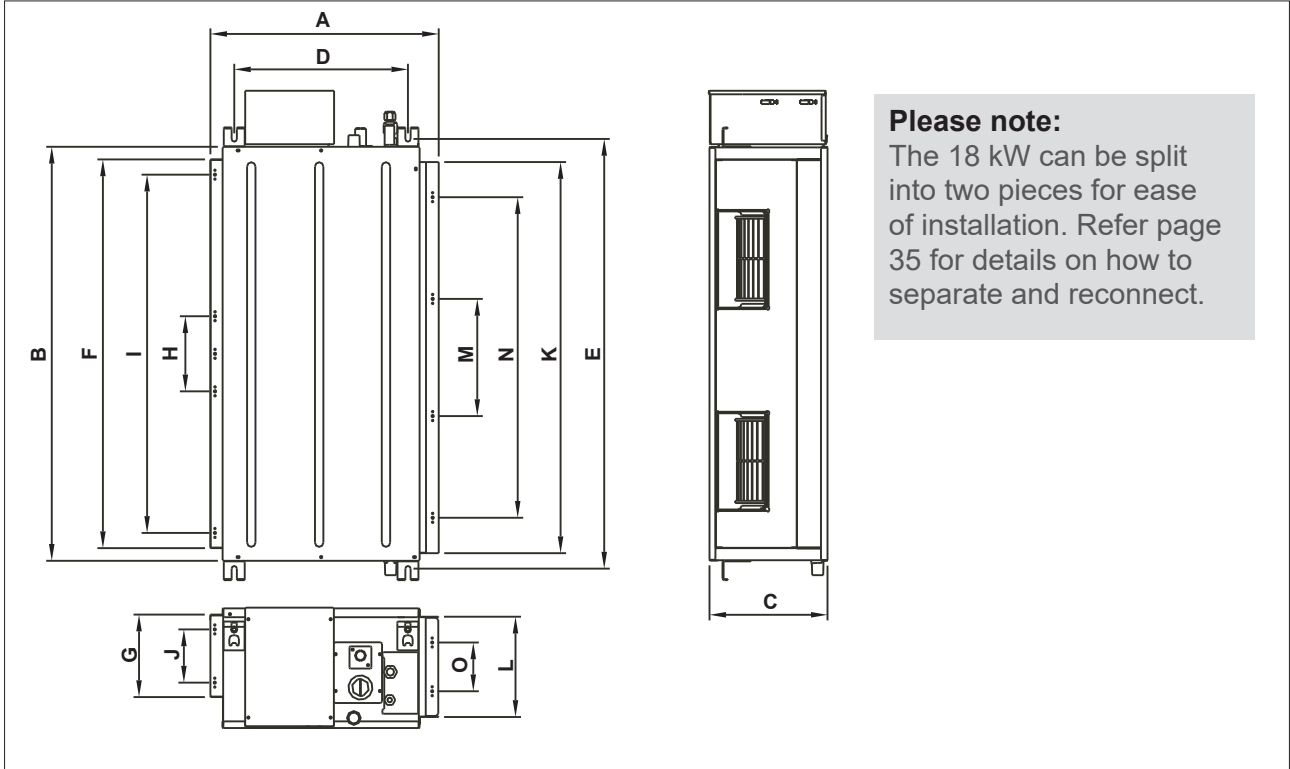

Model (kW)	Outline dim. (mm)			Mounted lug size (mm)		Air outlet opening size - symmetry of air outlet opening (mm)					Air inlet opening size - symmetry air inlet opening (mm)				
	A	B	C	D	E	F	G	H	I	J	K	L	M	N	O
11-15	625	1200	380	495	1236	1000	253	270	900	170	1145	334	325	925	130
18	858	1400	440 or 460	700	1436	1188	385	500	1000	280	1188	385	500	1000	280

# Indoor unit installation - hanging bolts

## Installing Ø10 hanging bolts (four bolts)

Check the ceiling type and isolate roof mountings from possible vibration.

When choosing where to locate the unit, consider the position of the refrigerant pipe and drains (confirming a minimum drain fall of 1:50). Make sure that the refrigerant pipe, drain pipes, indoor, and outdoor wiring can be routed and positioned adequately before hanging the unit. Once the unit is installed, fit off the refrigerant and connections.

Installation of the hanging screw bolts

- Strengthen roof beams as required to support full operating weight of the unit
- Securely mount the hanging screw bolts, and inspect for tightness.

## Wood

The mounting holes for the upper insulation panel are used for auxiliary positioning bolts. Put a mounting bracket transversely over the roof beams, and then install the hanging bolts.

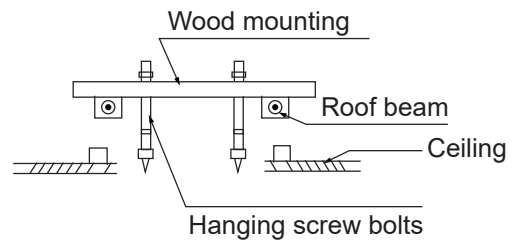
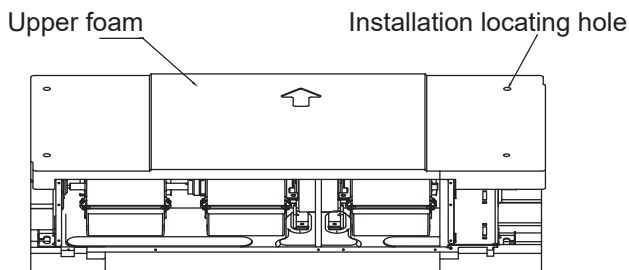

## New concrete bricks

Inlaying or embedding the screw bolts.

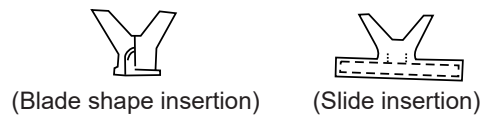

## Original concrete bricks

Use embedding screw bolts, crook and thread harness.

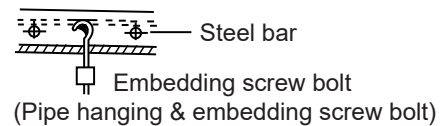

## Steel roof beam structure

Install a steel angle supporting bracket. The unit body must be completely aligned with the hole.

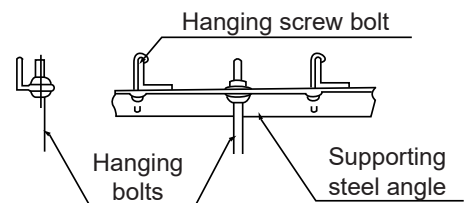

## Hanging the indoor unit

Hang the indoor unit onto the hanging screw bolts as shown. Install the indoor unit flat and level by using a spirit level. Uneven installation may cause condensate leaks.

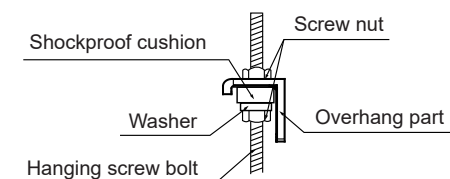

- Ensure the unit is not supporting the weight of the connected ducting.
- Install ducting in a way that allows for easy removal and maintenance.
- Set the unit static pressure to suit the ducting

# Indoor unit installation - air inlet direction

## How to adjust the air inlet from the rear to the underside of unit (7-9 kW models only)

Change the mounting positions of the ventilation panel and return air flange.

Take off the ventilation panel and flange. Bend the underside ventilation panel 90° along the dotted line to change it to a rear ventilation panel. Refer images below.

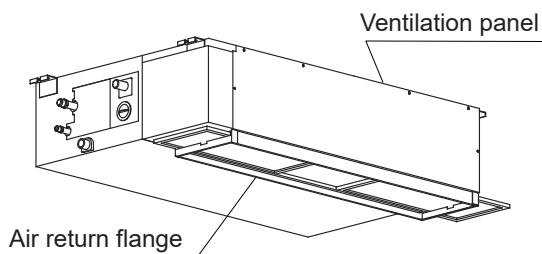
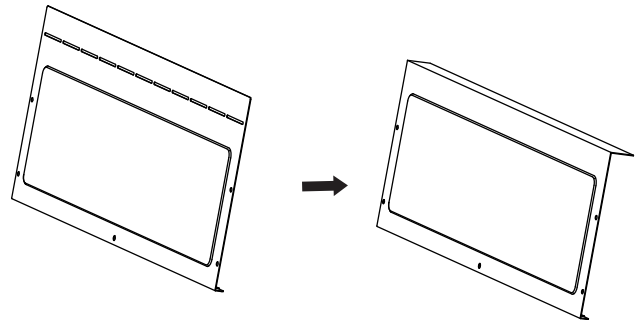
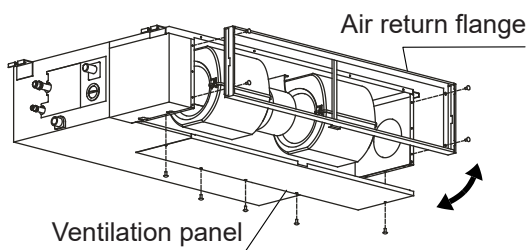

OR

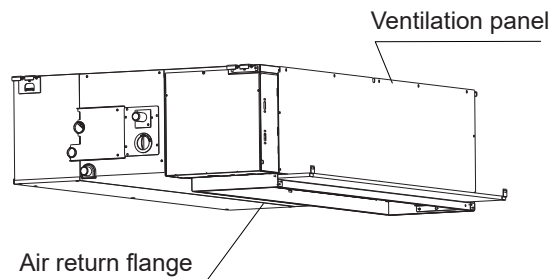

# Indoor unit installation - drain pipe

## Indoor drain pipe installation

Thermally insulate the drain pipe to prevent condensation and leakage. Attach the end of the drain hose to the unit's outlet pipe. Clip the end of the hose firmly in place with a pipe clamp.

The 11-18 kW models operate with positive pressure at the drain connections so a drain trap is required. The trap needs to be installed as close to the unit as possible. Make sure the top of the trap is below the connection to the drain pan to allow complete drainage.

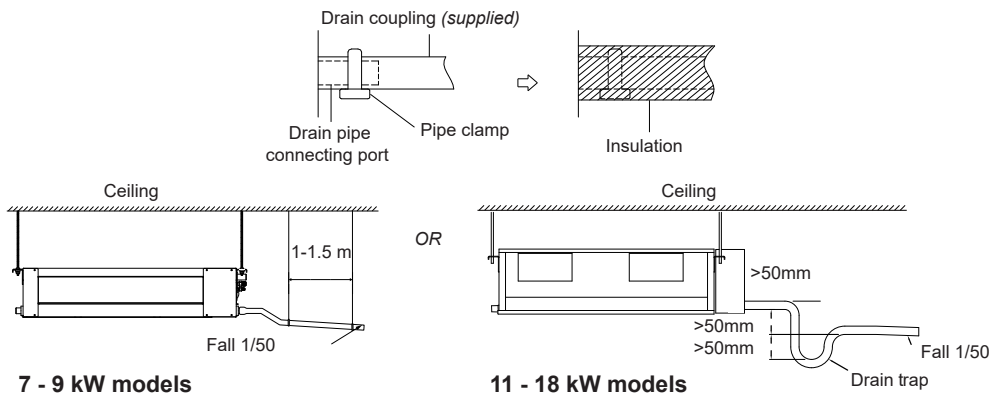

- If the drain pipe is bent or installed incorrectly, water may leak and cause a water-level switch malfunction.
- Thermally insulate the drain pipe.
- In HEAT mode the outdoor unit will discharge water, ensure the drain hose is placed in an appropriate area to avoid water damage.
- The drain pipe should slope downward at a gradient of at least 1/50 to prevent water from flowing back to the unit.
- To prevent sagging, place supports every 1-1.5 m.
- If sufficient fall cannot be achieved, connect the hose to the condensate pump. The initial lift pipe must start no more than 200 mm from the unit and the vertical rise must be no more than 55 mm above the unit, refer diagram below.
- To prevent air bubbles, keep the drain hose level or slightly tiled up (<75 mm).
- Before installing ductwork conduct a drainage test to ensure correct installation. For new builds, this test should be performed before the ceiling is installed.

7 - 9 kW models

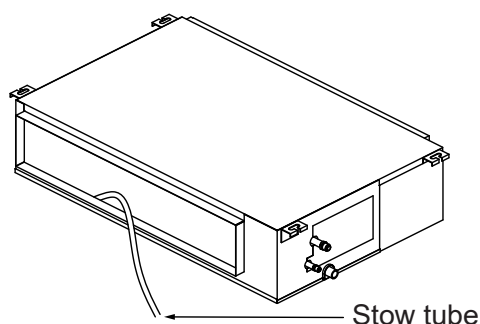

11 - 18 kW models

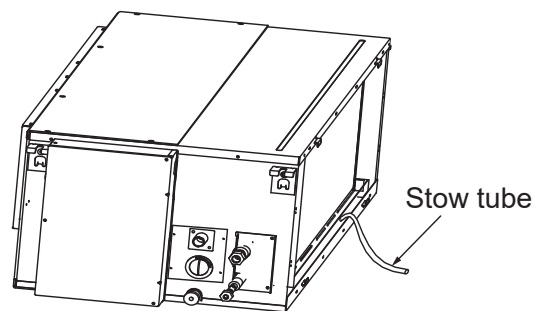

## Drain pipe installations using a pump

### 7-9 kW models

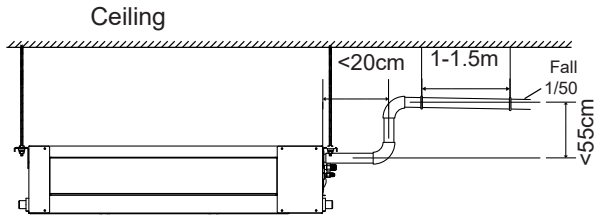

### 11-18 kW models

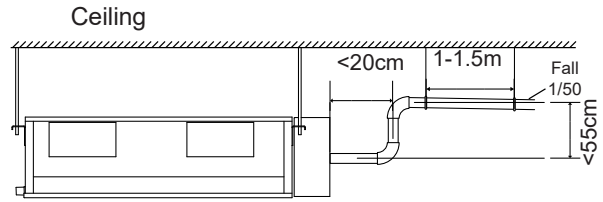

When connecting multiple drain pipes, install the pipes as illustrated below. If the condensate pump drain outlet is not used and one of the gravity drain outlets is used, fit the plug (from the gravity outlet) into the pump outlet and unplug the pump from the indoor PCB terminal CN13.

Pass the drain hose through the wall. Make sure the water drains to a safe location where it will not cause water damage or a slipping hazard.

### Units with a pump

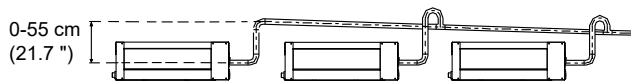

### Units without a pump

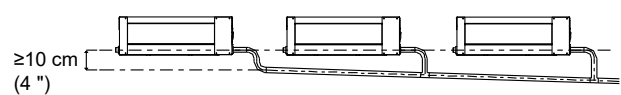

1. Remove the test cover, then fill the water pan with two litres of water.
2. During commissioning or performing a test run, turn on the unit in COOLING mode, you will hear the drain pump start. Check whether the water is discharging properly, a one minute lag is possible, depending on the length of the drain pipe. Check for water leaks from all joints. To force the system into COOLING mode refer 'Forced Cooling' on p.29.
3. Turn off the air conditioner and put the cap back on.

### 7 - 9 kW models

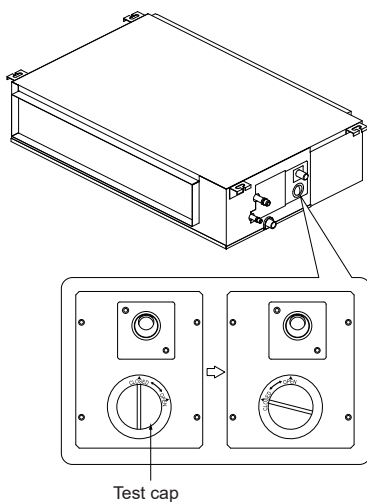

### 11 - 18 kW models

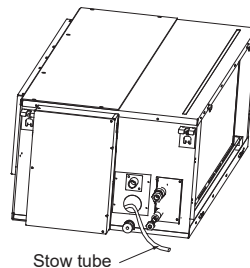
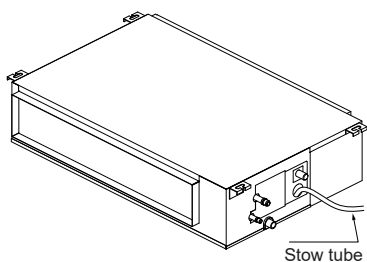
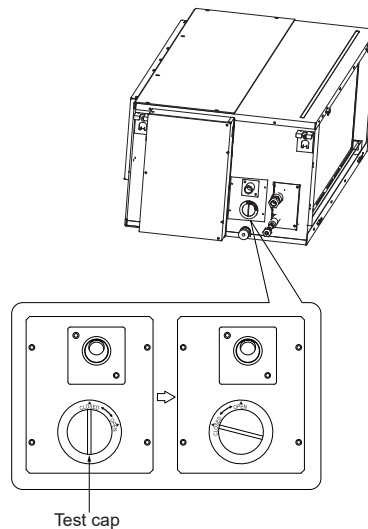

# Outdoor unit installation - location

## Clearances

The outdoor unit must be installed in accordance with the clearances outlined below. Note maintenance access, there must be sufficient room for installation and maintenance.

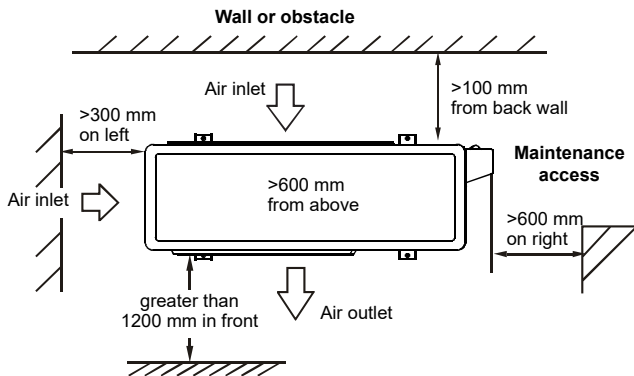

## Installation position

The outdoor unit must be located in a dry and well ventilated outdoor space on a supporting structure that is flat, horizontal, and can withstand the full operating weight of the unit. The base must be free of vibration.

Locate the outdoor unit as close as possible to the indoor unit to reduce performance losses. The refrigerant pipe length or height, or height difference between outdoor and indoor does not exceed the maximum allowable limits, refer p.18.

Select a location where the unit will not be subject to accumulation of snow, leaves or other seasonal debris. This may negatively impact the performance and longevity of the unit. Arrange so the air outlet is not blocked or obstructed.

In addition:

- Position so as to prevent operating noise being a nuisance to others
- Away from potential fire risks or flammable materials
- If possible, away from exposure to direct sunlight as this will negatively impact cooling performance

DO NOT install in the following locations:

- Near an obstacle that will block air inlets and outlets
- Near a public street, crowded areas, or where noise will disturb others
- Near animals or plants that will be harmed by hot air discharge
- Near any source of combustible gas
- In a location that is exposed to large amounts of dust
- In a location exposed to excessive amounts of salty air

In severe environments (geothermal areas or areas with caustic gases) take precautions such as applying additional corrosion protection to exposed components.

## Special considerations for heavy wind exposure

For installations prone or exposed to strong prevailing winds such as coastal areas, please ensure the unit is sited appropriately by placing it lengthwise along the wall to reduce any negative impact on the condenser fans. Install the unit so that the air outlet fan is at a 90° angle to the direction of the wind. If needed build a barrier in front of the unit to protect it from extremely heavy winds.

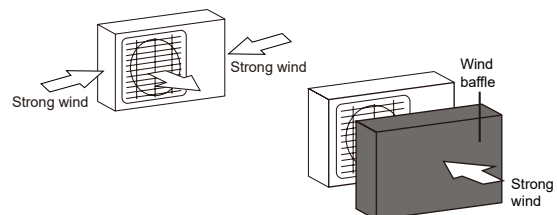

# Outdoor unit installation - mounting dimensions

Prepare the installation base of the unit according to the dimensions below.

Model	Outdoor unit W x D x H	Mounting dimensions	
		Distance A	Distance B
7 kW	890 x 342 x 673 mm	663 mm	354 mm
9-11 kW	946 x 410 x 810 mm	673 mm	403 mm
13-18 kW	952 x 415 x 1333 mm	634 mm	404 mm

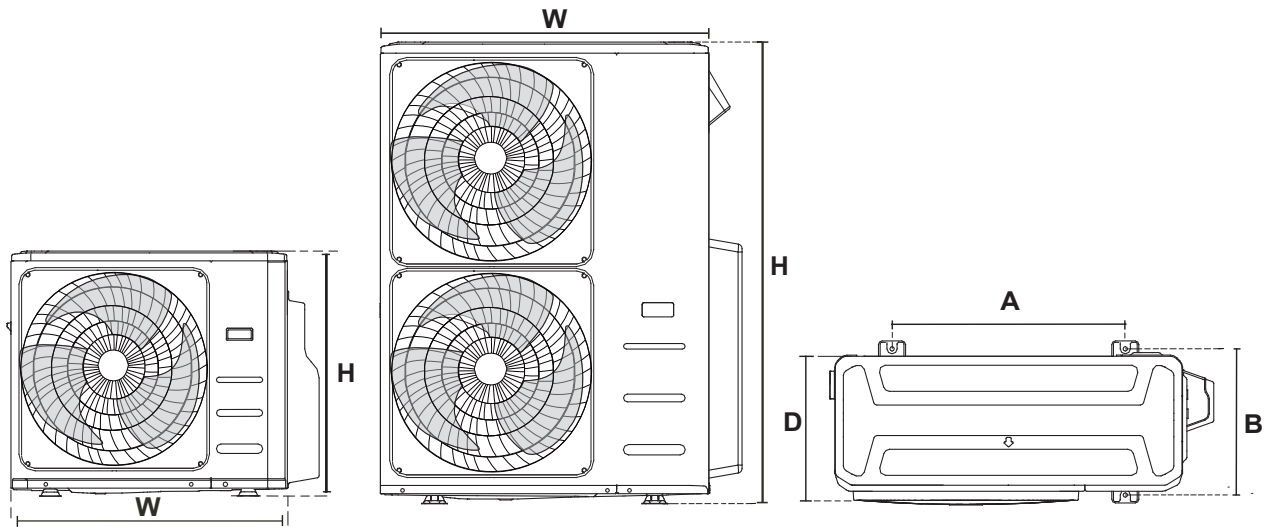

## Multiple units

	L	A
$L \leq H$	$L \leq \frac{1}{2} H$	25 cm or more
$L > H$	$\frac{1}{2} H < L \leq H$	30 cm or more
	Cannot be installed	

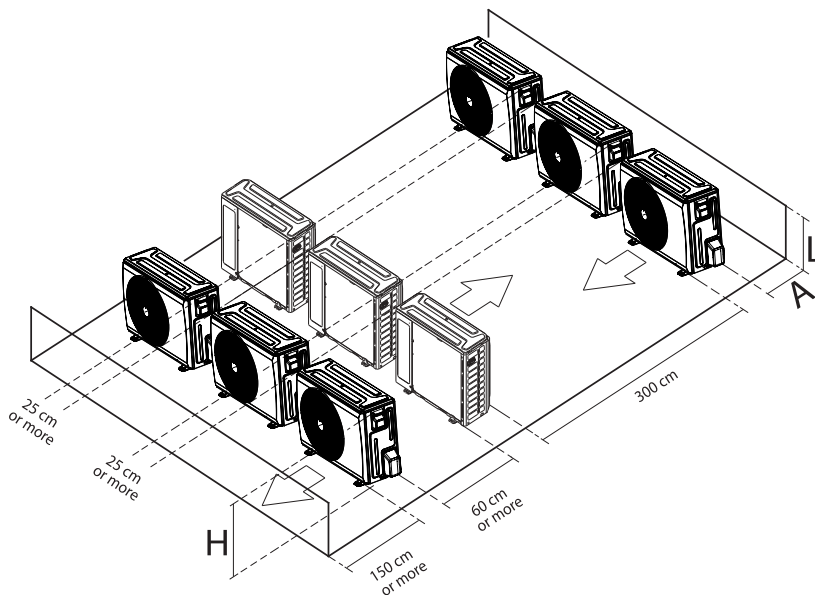

# Outdoor unit - drain joint and anchoring

## Installing the drain joint

Before bolting the outdoor unit in place, install the drain joint at the bottom of the unit. There are two different types of drain joint depending on the outdoor model.

### If the drain joint comes with a rubber seal

1. Fit the rubber seal on the end of the drain joint that will connect to the outdoor unit.
2. Insert the drain joint into the hole in the base pan of the unit.
3. Rotate the drain joint 90° until it clicks in place facing the front of the unit.
4. Connect a drain hose extension (not included) to the drain joint to redirect the water from the unit during heating mode.

### If the drain joint doesn't come with a rubber seal

1. Insert the drain joint into the hole in the base pan of the unit, it will click into place.
2. Connect a drain hose extension (not supplied) to the drain joint to redirect water from the unit during heating mode.

In cold climates, make sure the drain hose is as vertical as possible to ensure quick water drainage. If the water drains too slowly, it can freeze in the hose and flood the unit. Insulating the drain hose in cold climates is recommended.

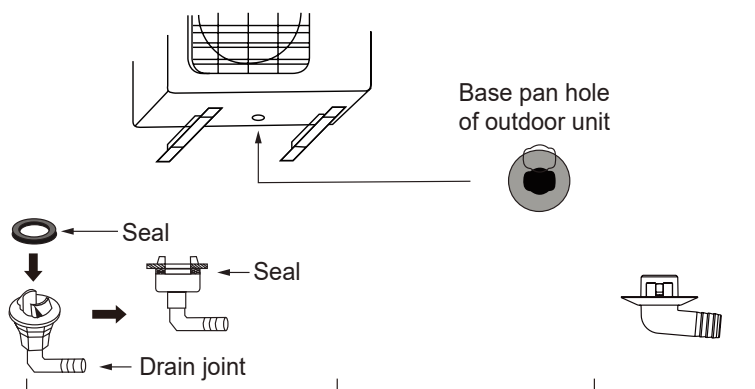

## Anchoring the outdoor unit

The outdoor unit can be anchored to the ground or to a wall mounted bracket with bolts (M10). Prepare the installation base of the unit according to the dimensions on the previous page.

To reduce the transmission of vibration and noise, a waffle pad or something similar shall be installed beneath the unit at each anchor point.

# Refrigerant piping connection

When connecting refrigerant piping do not let substances or gases other than the specified refrigerant enter the unit. The presence of other gases or substances will lower the unit's capacity, and can cause abnormally high pressure in the refrigeration cycle. This can cause explosion and injury.

The branching pipe must be installed horizontally. An angle of more than 10° may cause malfunction. Insulate the gas and liquid piping to prevent condensation.

DO NOT install the connecting pipe until both the indoor and outdoor units have been installed.

## Pipe length

Ensure the length of the refrigerant pipe, the number of bends, and the drop height between the indoor and outdoor units meets the requirements shown below.

Maximum length and drop height		
Model	Maximum equivalent pipe length	Maximum vertical separation
7 kW	50 m	25 m
9 - 18 kW	75 m	30 m

## Oil traps

If oil flows back into the unit's compressor this might cause liquid compression or deterioration of oil return. Oil traps in the rising gas piping can prevent this. For units less than 10.5 kW, an oil trap should be installed every 6 m of vertical suction line riser. For units greater than or equal to 10.5 kW, an oil trap should be installed every 10 m of vertical suction line riser.

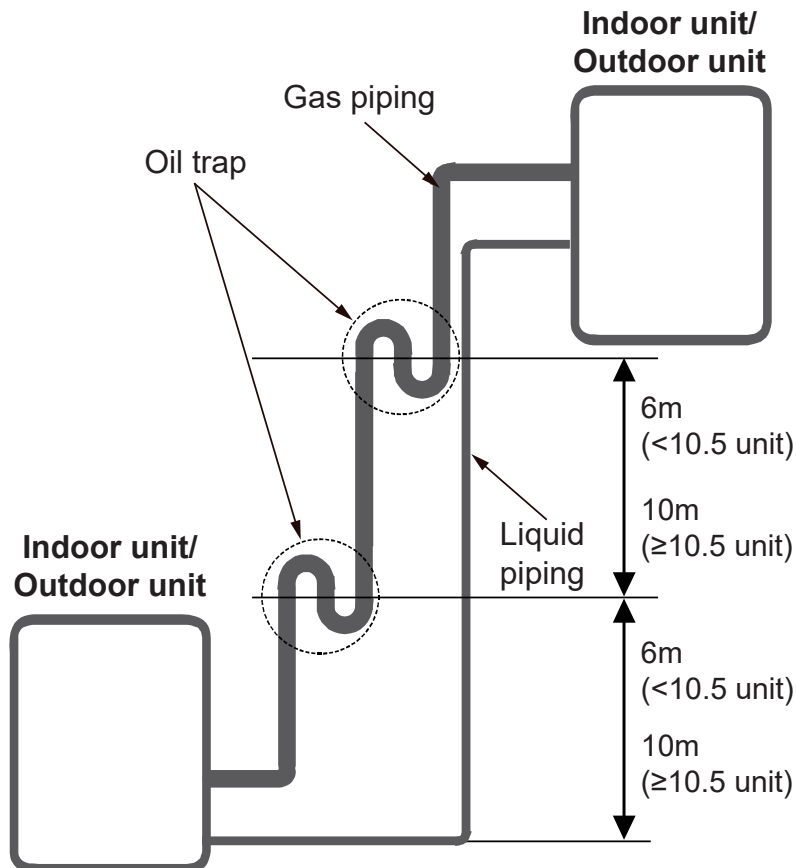



Avoid direct contact with bare pipes as this may result in burns or frostbite.

### Step 1: Cut pipes

When preparing refrigerant pipes, take extra care to cut and flare them properly. This will ensure efficient operation and minimise the need for future maintenance. Be careful not to damage, dent, or deform the pipe while cutting. This will drastically reduce the heating efficiency of the unit.

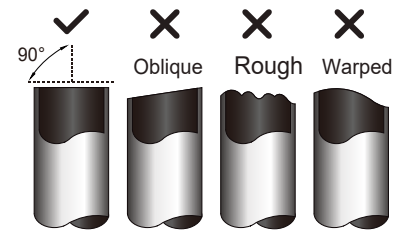

- Measure the distance between the indoor and outdoor units.
- Using a pipe cutter, cut the pipe a little longer than the measured distance.
- Make sure that the pipe is cut perfectly at a 90° angle.

### Step 2: Remove burrs

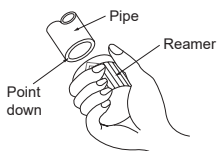

Burrs affect the airtight seal of the refrigerant piping connection. They must be completely removed. Hold the pipe at a downward angle to prevent burrs from falling into the pipe. Using a reamer or deburring tool, remove all burrs from the cut section of the pipe.

### Step 3: Flare pipe ends

Proper flaring is essential to achieve an airtight seal. After removing burrs from the cut pipe, seal the ends with PVC tape to prevent foreign materials from entering the pipe. Sheath the pipe with insulating material.

Place the flare nuts on both ends of the pipe. Make sure they are facing in the right direction, as you can't put them on or change direction after flaring.

Remove PVC tape from the ends of the pipe when ready to perform flaring work. Clamp flare form on the end of the pipe. The end of the pipe must extend beyond the flare form.

Place flaring tool onto the form. Turn the handle of the flaring tool clockwise until the pipe is fully flared. Flare pipe in accordance with the dimensions below then remove the flaring tool and flare form, then inspect the end of the pipe for cracks and even flaring.

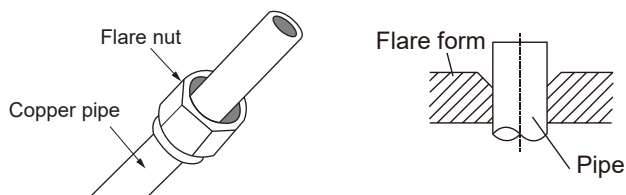

### Piping extension beyond flare form

Pipe gauge	Flare nut outer	Tightening torque	Flared dimensions (A)		Flare shape
			Min.	Max.	
Ø 9.52 (Ø <sup>3</sup> / <sub>8</sub> ")	22 mm	33-42 N.m	13.2 mm	13.5 mm	
Ø12.7 (Ø <sup>1</sup> / <sub>2</sub> ")	24 mm	50-62 N.m	16.2 mm	16.5 mm	
Ø16 (Ø <sup>5</sup> / <sub>8</sub> ")	27 mm	63-77 N.m	19.2 mm	19.7 mm	
Ø19 (Ø <sup>3</sup> / <sub>4</sub> ")	-	90-110 N.m	23.2 mm	23.7 mm	

#### Step 4: Connect pipes

Connect the copper pipes to the indoor unit first, then connect to the outdoor unit. Connect the low pressure pipe, then the high pressure pipe.

When connecting the flare nuts, apply a thin coat of compatible refrigeration oil to the flared ends of the pipes. Align the centre of the two pipes that will be connected. Tighten the flare nut as tightly as possible by hand. Using a spanner, grip the nut and use a torque wrench to tighten the flare nut according to the torque values in the table on the previous page.

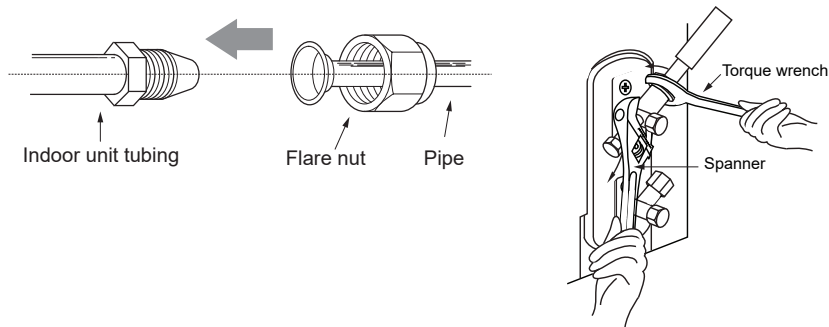

Carefully bend the tubing in the middle. DO NOT bend the tubing more than 90° or more than three times.

After connecting the copper pipes to the indoor unit, wrap the power cable, signal cable, and then the piping together with the binding signal tape. DO NOT intertwine or cross the signal cable with other wires, while bundling these items together.

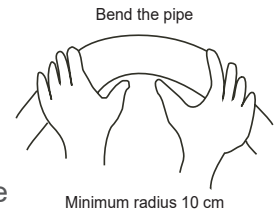

Make sure the pipe is connected correctly. Overtightening may damage the bell mouth and under tightening may lead to leakage.



#### Please note:

- Pipe run must be supported every 2 m
- R32 flammable refrigerant labels must be placed on the pipe every 2 m
- Insulate all the piping, including the valves of the outdoor unit.

# Wiring and controllers



Before performing any electrical or wiring work, turn off the mains power to the system.

- If the unit has an auxiliary electric heater, it **MUST** be installed at least 1 m away from combustible materials.
- To avoid getting an electric shock, **NEVER** touch the electrical components immediately after the power supply has been turned off. After turning off the power, always wait ten minutes or more before you touch any electrical components.
- Ensure that you **DO NOT** cross your electrical wiring with your signal wiring. This may cause distortion and interference.
- The unit **MUST** be connected to the main outlet. Normally, the power supply must have a impedance of 32 ohms.
- No other equipment should be connected to the same power circuit.
- Connect the outdoor wires before connecting the indoor wires.

## Controllers

The below controllers may be configured to all the models detailed in this manual.

### Looms

Specification: 2-core shielded cable 0.5 mm sq x 18 mm long The length of the controller loom may be up to a maximum of 40 m.

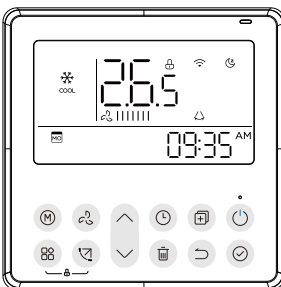

**Standard wall controller**  
CNTRLDRCINW



**Deluxe wall controllers**  
CNTRLDRCIPB (black face)  
CNTRLDRCIPW (white face)

# Power and communication connections

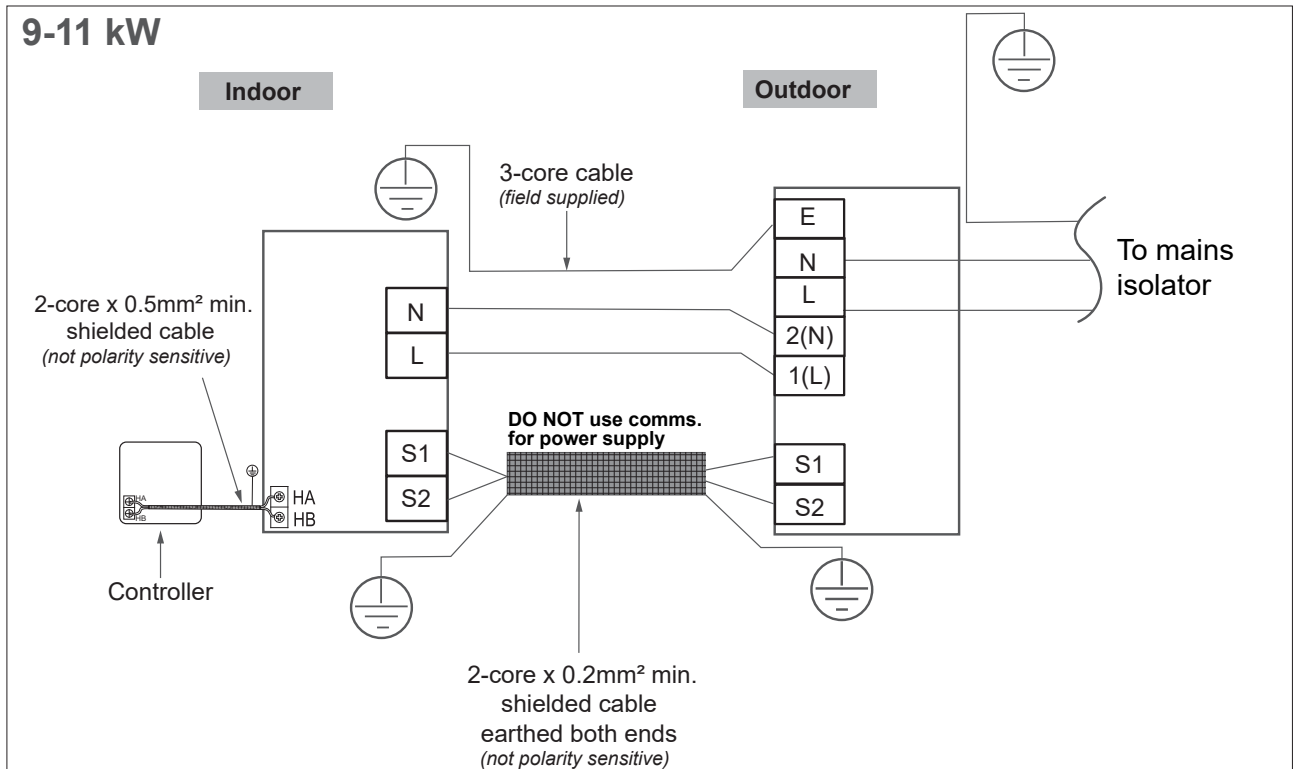
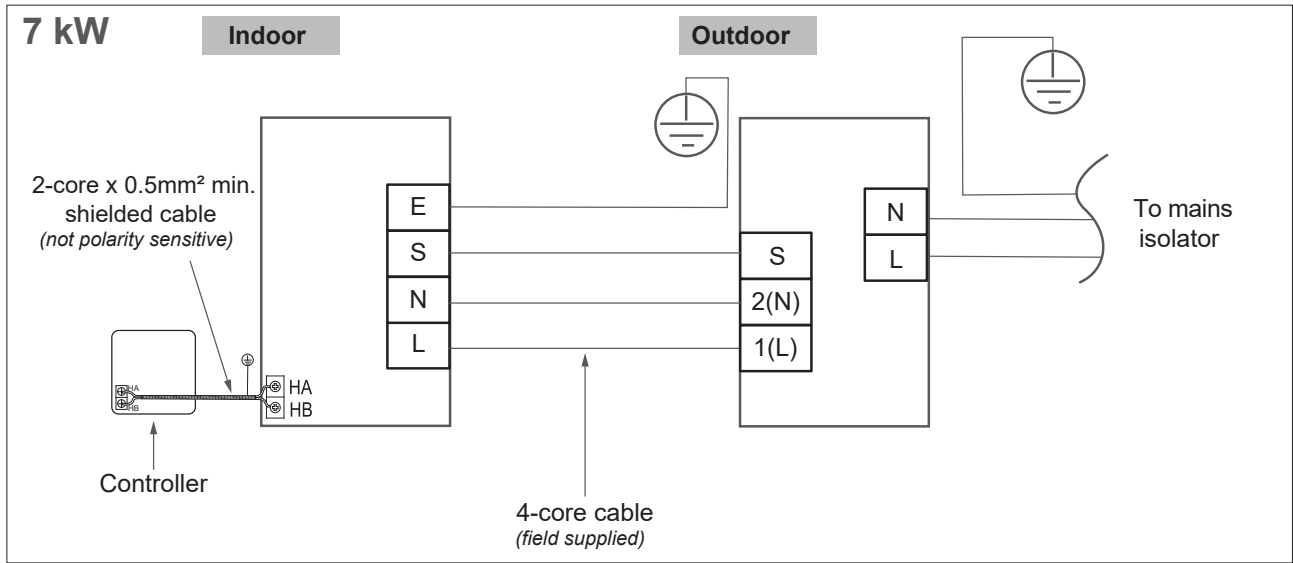

# 13-18 kW

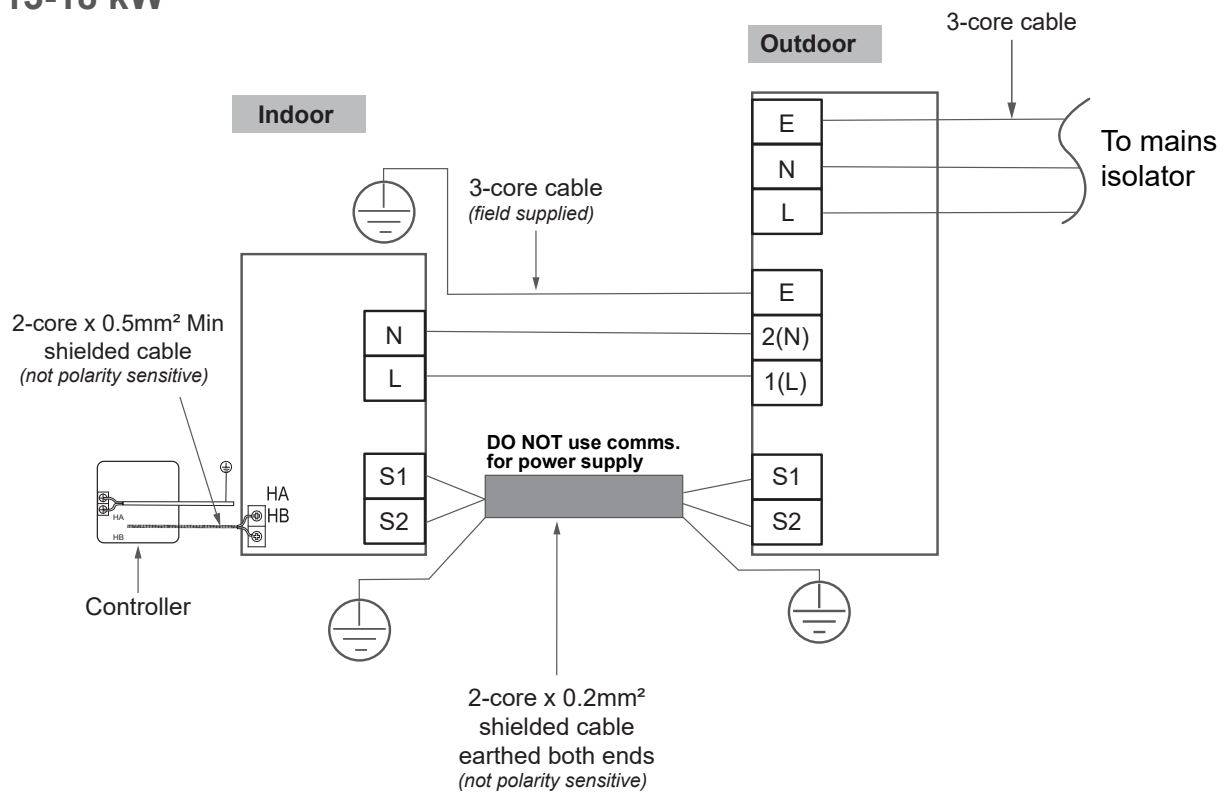

# Outdoor unit wiring

Prepare the cable for connection using the below table as reference. When connecting the wires, strictly follow the wiring diagram found inside the electrical box cover.

Rated current of appliance	Nominal cross-sectional area (mm <sup>2</sup> )
>3 and ≤6 A	0.75 mm <sup>2</sup>
>6 and ≤10 A	1 mm <sup>2</sup>
>10 and ≤16 A	1.5 mm <sup>2</sup>
>16 and ≤25 A	2.5 mm <sup>2</sup>
>25 and ≤32 A	4 mm <sup>2</sup>
>32 and ≤40 A	6 mm <sup>2</sup>

## Choose the right cable size

The size of the power supply cable, signal cable, fuse, and switch needed is determined by the maximum current of the unit. The maximum current is indicated on the dataplate located on the side panel of the unit. Refer to this dataplate to choose the right cable, fuse, or switch.

Using wire strippers, strip the rubber jacket from both ends of the signal cable to reveal approximately 15 cm of wire.

Strip the insulation from the ends, and using a wire crimper, crimp u-lugs on the ends.

## Connection

1. Remove the two screws fixed on the front panel and side panel, then take it down to perform the wire connection (outdoor unit A). Unscrew the electrical wiring cover and remove it (outdoor unit B).
2. Connect the u-lugs to the terminals. Match the wire colours / labels with the labels on the terminal block. Firmly screw the u-lug of each wire to its corresponding terminal.
3. Clamp down the cable with the cable clamp.
4. Insulate unused wires with electrical tape. Keep them away from any electrical or metal parts.
5. Reinstall the cover of the electrical control box.

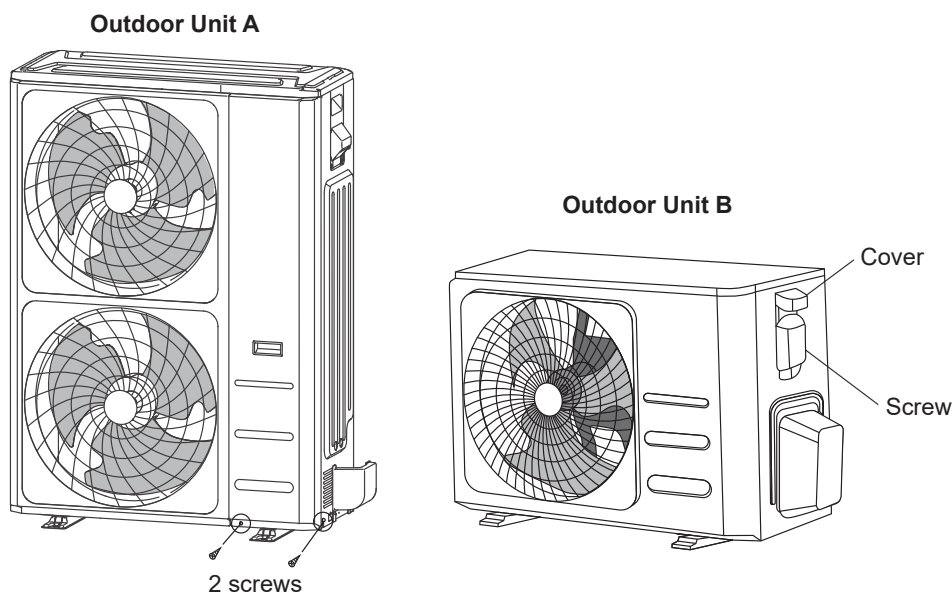

### Power and communication access to outdoor unit

1. Remove the two fixing screws as shown on previous page (outdoor unit A), and remove the front panel.
2. Remove the power and communication knock-outs with an appropriate tool.

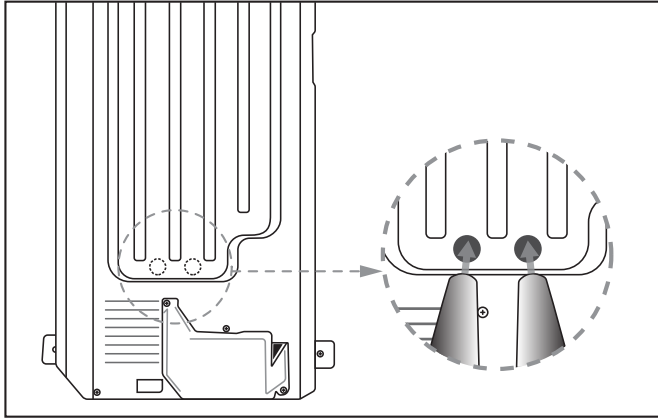

3. Feed power and communication conduits separately through the knockouts and secure cables inside of the cabinet.
4. Power and communication looms must remain secured separately inside of the cabinet.

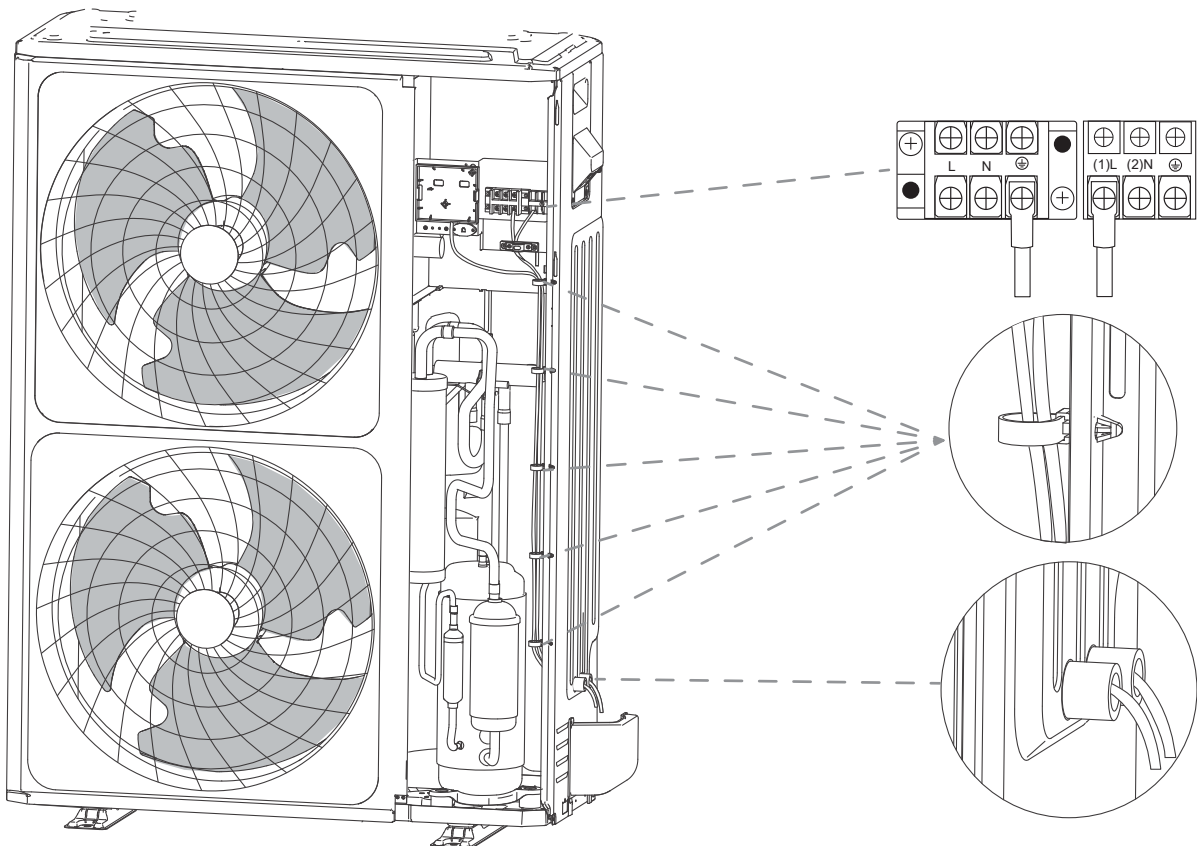

# Indoor unit wiring



The refrigerant circuit can become very hot. Keep the interconnection cable away from the copper tube.

1. Prepare the cable for connection.
  - a. Using wire strippers, strip the rubber jacket from both ends of the signal cable to reveal approximately 15 cm of wire.
  - b. Strip the insulation from the ends of the wires.
  - c. Using a wire crimper, crimp the u-lugs to the ends of the wires.
2. Remove the cover of the electrical control box on your indoor unit.
3. Connect the u-lugs to the terminals. Match the wire colours / labels with the labels on the terminal block. Firmly screw the u-lug of each wire to its corresponding terminal. Refer to the serial number and wiring diagram located on the cover of the electrical control box.
4. Clamp down the cable with the cable clamp. The cable must not be loose or pull on the u-lugs.
5. Reattach the electrical box cover.

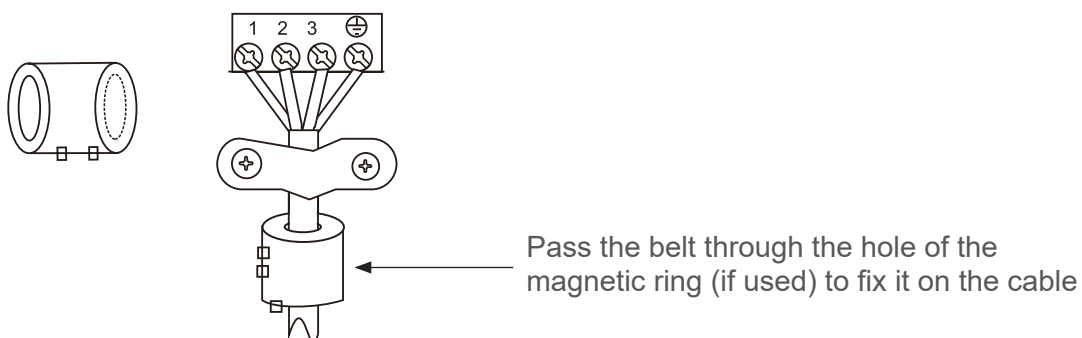
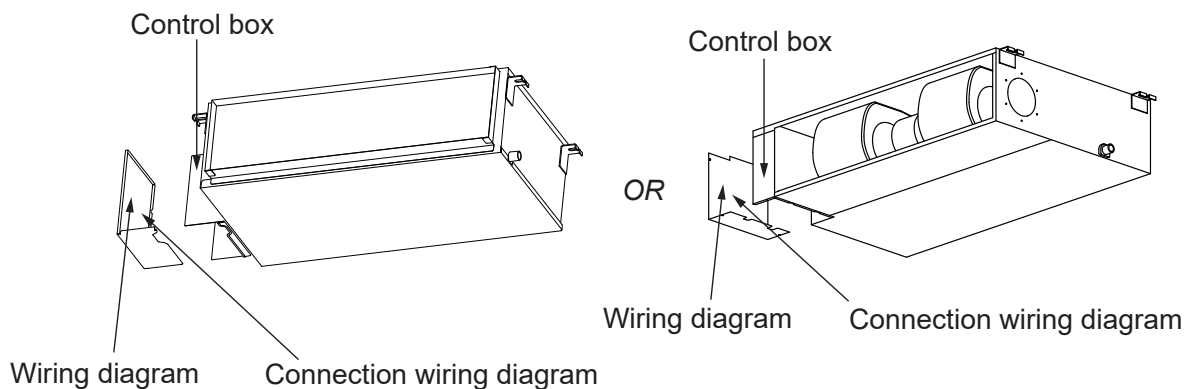

# Pressure and leak test

## Dry nitrogen pressure test

Using dry nitrogen, pressure test interconnecting pipework from the outdoor unit inclusive of the fan coil unit, to the maximum allowable pressure as indicated on the data label of the outdoor unit. For more information refer to AS/NZS 5149.2.

Air, oxygen, acetylene or refrigerants shall not be used for pressure testing purposes.



Wear the correct PPE at all time when working with refrigerants and conducting high pressure tests.

## Leak testing

1. Outdoor unit service ports shall be closed or front sealed before commencing.
2. Connect dry nitrogen bottle with gauge set to the suction line access point and ensure all fittings are tight.
3. Open the dry nitrogen bottle valves and set test pressure to the maximum allowable pressure as indicated on the outdoor unit's data label. **DO NOT EXCEED.**
4. Use an approved leak detector to assess all joints for leaks and from the outdoor service valves to the connections at the indoor unit. If no leaks are detected close the dry nitrogen valves.
5. With care, safely and slowly commence removal of the pressure supply line from the dry nitrogen bottle using the bleed to release technique.
6. Once the system pressure has been removed safely you may remove the connecting line from the service valve on the appliance

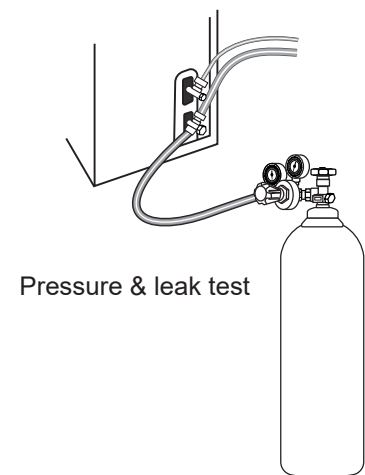

# Evacuation

Air and foreign matter in the refrigerant circuit can cause abnormal rises in pressure. This can damage the system, reduce its efficiency, and may cause injury. Use a vacuum pump and vacuum stat to evacuate the refrigerant circuit and remove any non-condensable gas and moisture from the system.

Evacuation **MUST** be performed after completion of the dry nitrogen pressure test. Before performing evacuation check to make sure:

- The connective pipes between the indoor and outdoor units are connected properly
- All wiring is connected correctly

## Evacuation

1. Vacuum the indoor interconnecting pipework to a minimum of 500  $\mu\text{m}$  of Hg.
2. Isolate the vacuum pump from the system and let the vacuum stand for one hour to ensure vacuum is maintained at 600  $\mu\text{m}$  of Hg or below. For more information, refer to 'Refrigerant handling code of practice 2007'.
3. If the system vacuum pressure decreases to a value greater than 600  $\mu\text{m}$  after one hour of standing, the pressure and leak test needs to be repeated to find the leak location.
4. If the system vacuum pressure remains below 600  $\mu\text{m}$  after one hour of standing, fasten the Schrader valve and remove all vacuum fittings.

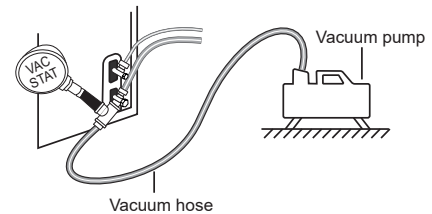

## Charging the system

1. Unscrew the cap from the packed valve (high pressure valve).
2. Insert hexagonal wrench into the packed valve and open the valve by turning the wrench anti-clockwise. Continue to turn until valve is fully back seated, and listen for the refrigerant entering the circuit.
3. Tighten the valve caps on the two valves by hand. You may tighten it further using a torque wrench if needed.

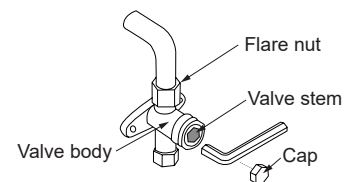
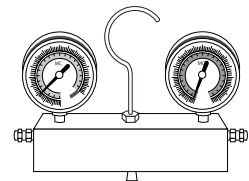

## Adding refrigerant

Some systems require additional charge depending on pipe lengths. The standard pre-charged pipe length for all models is 15 m. For pipe lengths greater than 15 m, add 24 g/m. For less than 15 m there is no requirement to remove charge.

The refrigerant must be charged from the service port on the outdoor unit's low pressure valve.



When opening the valve stems, turn the hexagonal wrench anti-clockwise until it hits against the back stop. Do not try to force the valve to open further.

Check to make sure there is no refrigerant leak after completing the installation. If there is a leak, ventilate the area immediately and evacuate the system.

Never mix refrigerant types.

# Test run

## Before the test run

The test run must be performed after the entire system has been installed. Failure to perform the test run may result in unit damage, property damage, or personal injury. Confirm the following before performing the test.

- ✓ Indoor and outdoor units are properly installed
- ✓ Piping and wiring are properly connected
- ✓ No obstacles near the inlet / outlet of the unit that might cause performance or product malfunction
- ✓ Refrigeration system does not leak
- ✓ Drainage system is unimpeded and draining to a safe location
- ✓ Insulation is properly installed
- ✓ Earthing wires are properly connected
- ✓ Length of the piping and additional refrigerant stow capacity have been recorded
- ✓ Power voltage is the correct voltage for the air conditioner

## Forced cooling

To force the system into Forced Cooling (FC), do the following:

1. At the indoor unit remove the control access panel to access the control board (shown below).
2. Press the 'Manual' button twice or until 'FC' appears in the LED display, the system will now run in the below sequence.

Compressor and outdoor fan run continuously while the indoor fan runs at low to medium speed. After thirty minutes the system will switch to auto mode with a 24 °C setting.

When the system receives a signal from the primary wall control, such as switch on, switch off, timer on, timer off, mode setting, fan speed setting, sleep mode setting or follow me setting, all forced operation sequences will cease, and control will revert to the wall control.

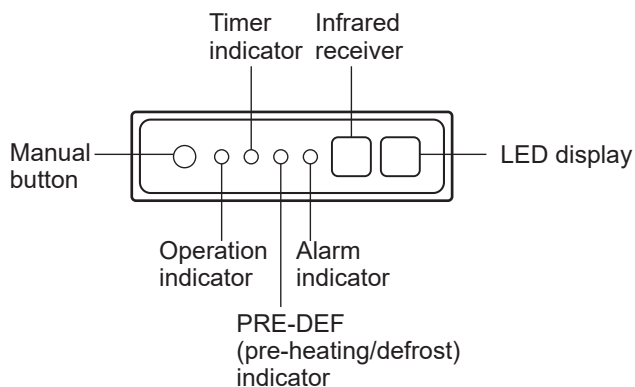

## **Test run instructions**

Set the air conditioner to COOL mode.

### For the indoor unit

- Ensure the controller buttons work properly.
- Double check to see if the room temperature is being registered correctly.
- Ensure the indicators on the controller work properly.
- Ensure the manual button on the indoor unit works properly.
- Check the drain system is unimpeded and draining properly.
- Ensure there is no vibration or abnormal noise during operation.

### For the outdoor unit

- Check for refrigerant leaks
- Ensure there is no vibration or abnormal noise during operation.
- Ensure the noise generated by the unit will not disturb neighbours or pose a safety hazard.

### Drainage test

- Ensure the drainpipe flows smoothly, for new builds perform this test before finishing the ceiling.
- Remove the test cover, add 2 L of water to the tank through the attached tube.
- Turn on the main power switch and run the air conditioner in COOL mode.
- Listen to the sound of the drain pump to see if it makes any unusual noises.
- Check to see water is discharged, it may take up to one minute.
- Make sure there are no leaks in any of the piping.
- Stop the air conditioner. Turn off the main power switch and reinstall the test cover.

# Appendix 1: Fan performance charts

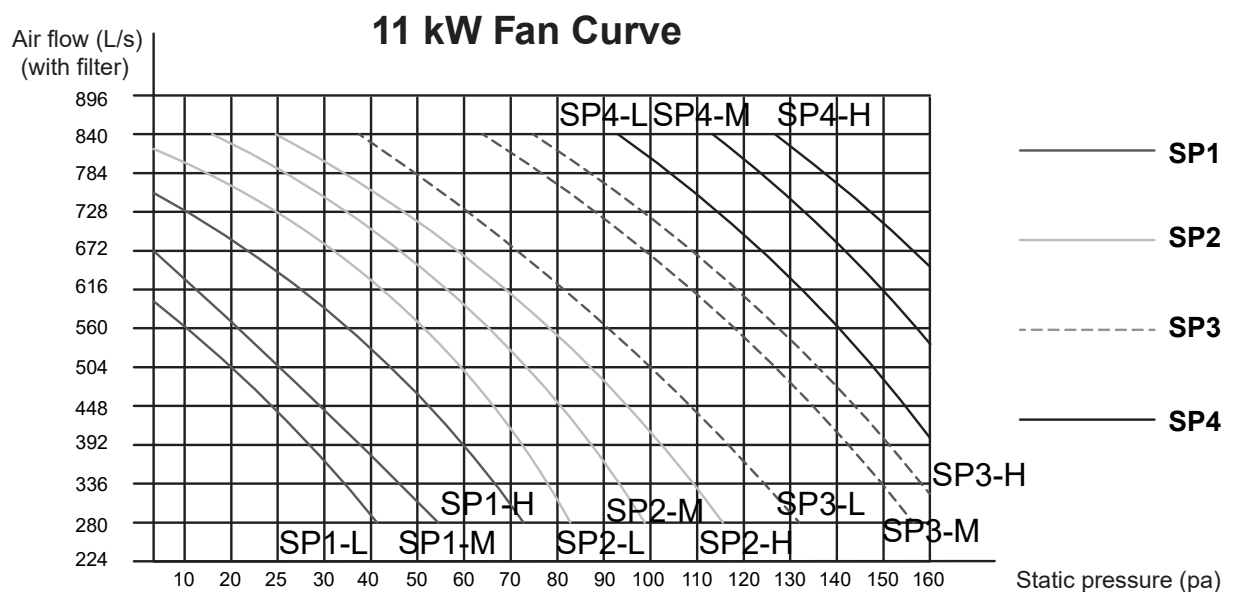
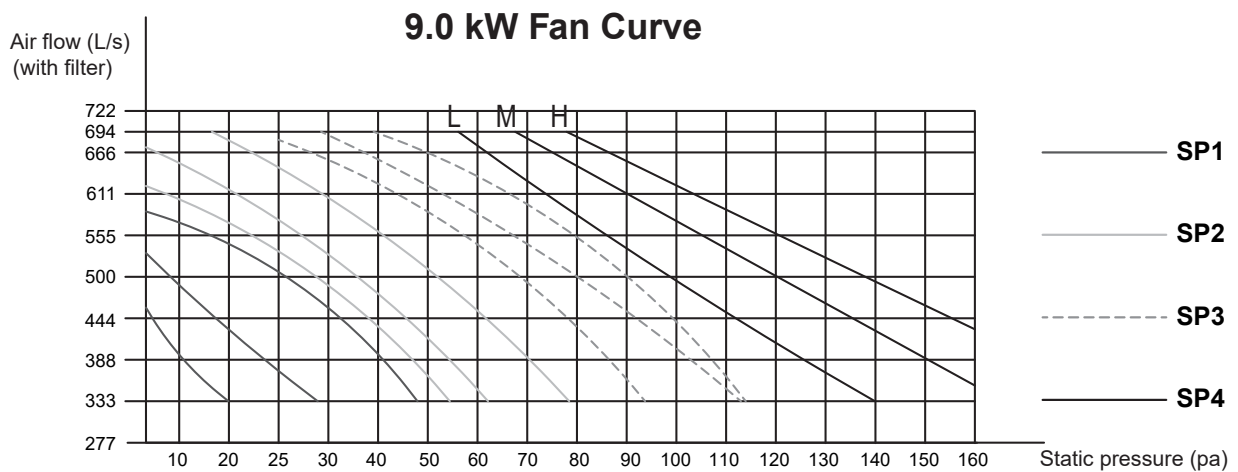
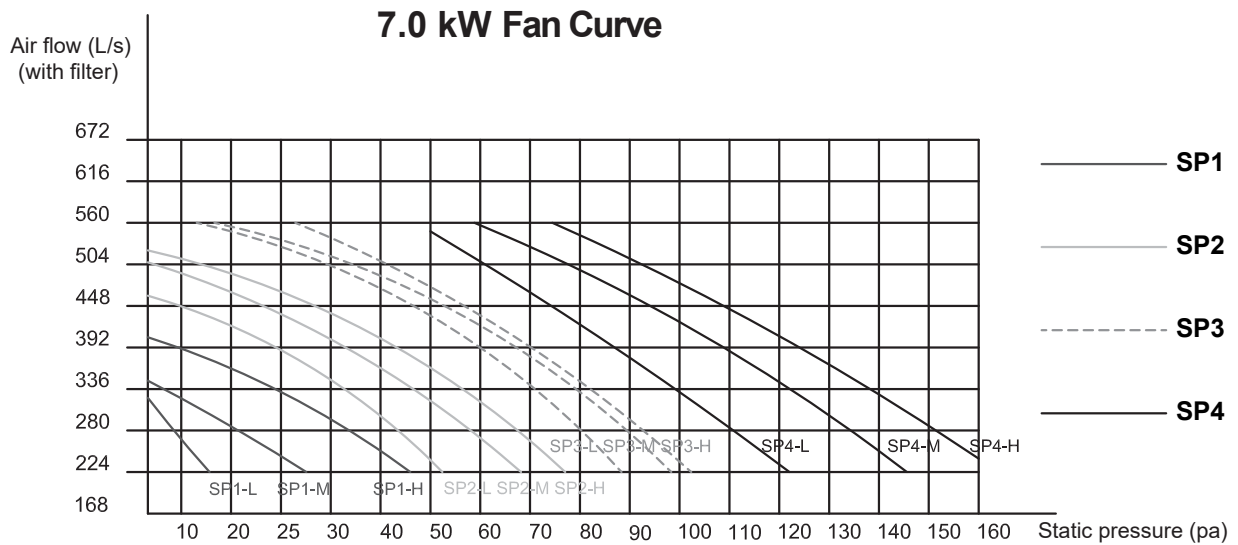

### 13 kW Fan Curve

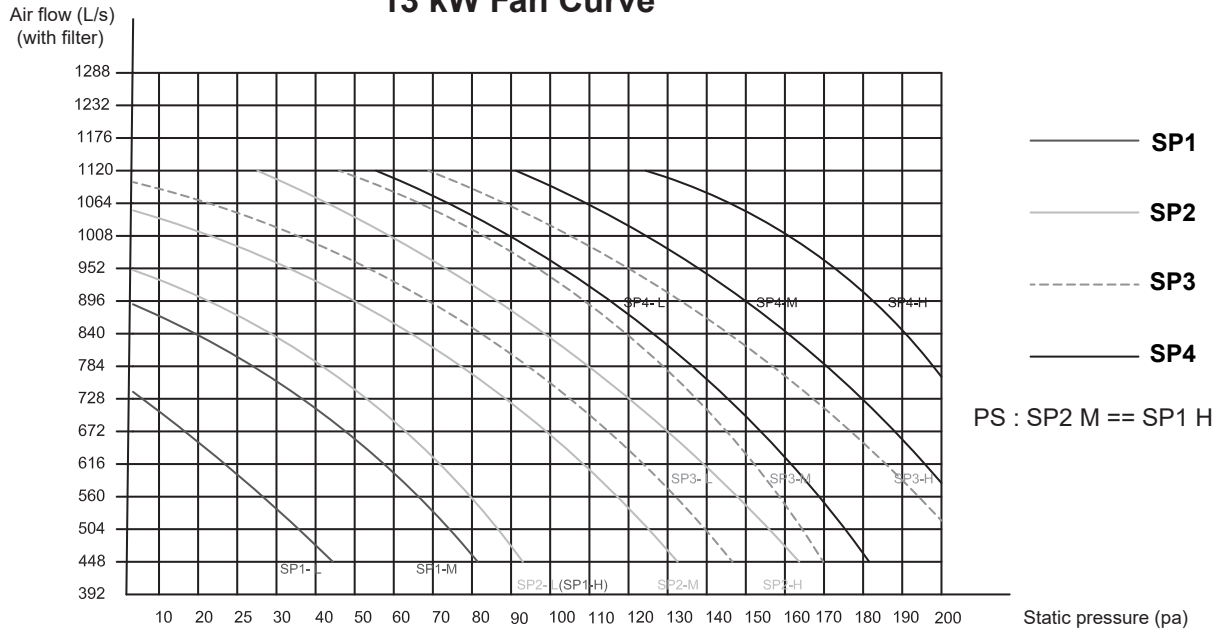

### 15 kW Fan curve

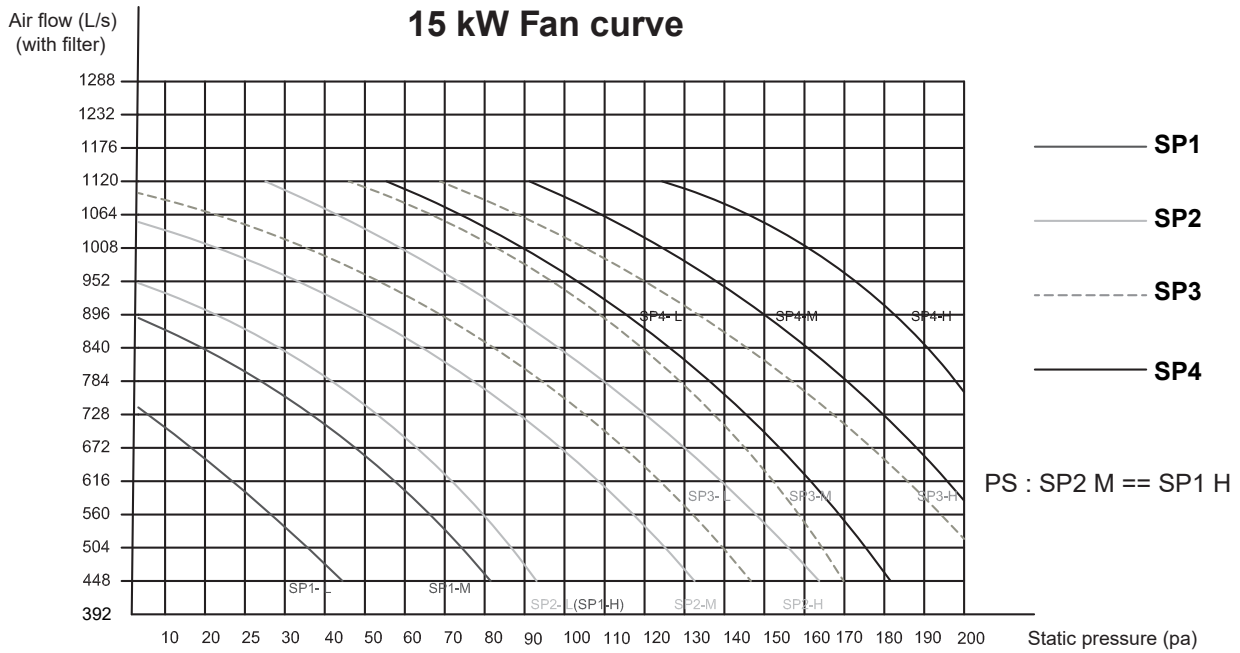

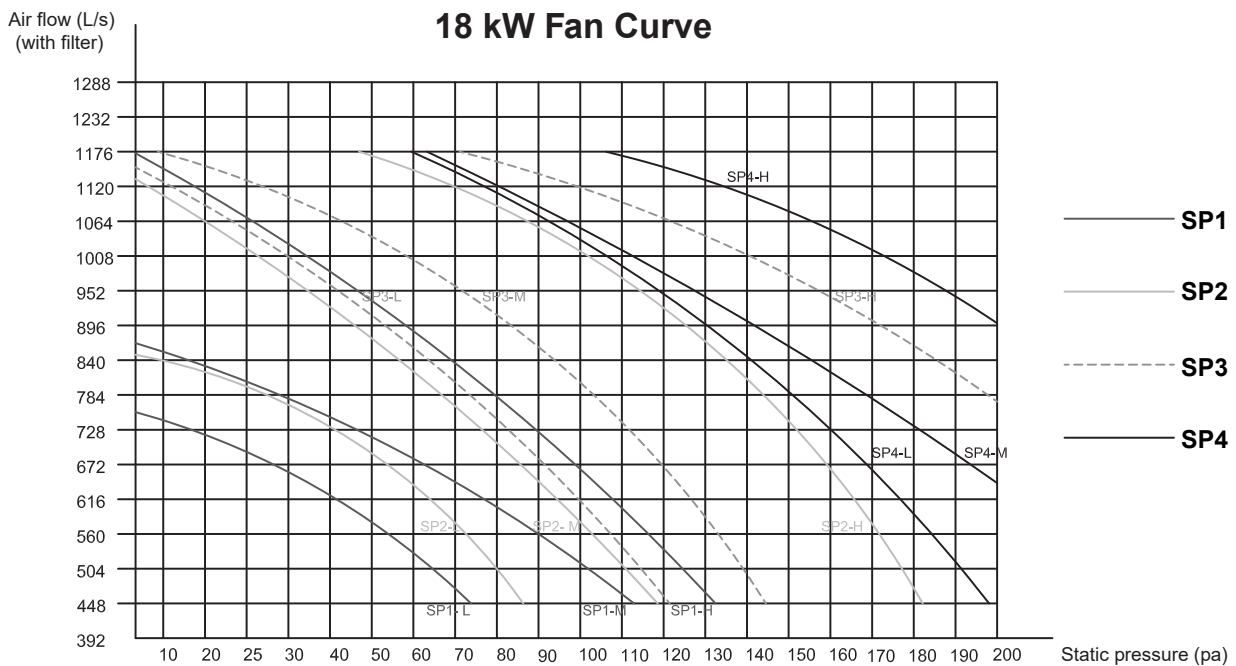

## Setting the system static pressure

Models are supplied with the Auto Fan (AF) setting enabled and the Static Pressure (SP) setting disabled, or set to 0. To disable AF and enable the desired system SP setting via the controller, do the following:



### Deluxe Controller (CNTRLDRCPW/B)

1. Turn the system OFF at the controller.
2. Press the menu and power buttons at the same time—hold for 7 seconds.
3. Select 'Setting' and press enter (tick).
4. M1 will display on the screen, press enter.
5. Press the down button to highlight 'Channel 8' and press enter.
6. When AF mode is enabled the static pressure of the system will be automatically selected.
7. With AF mode disabled, change the system static pressure manually by selecting 'Static Pressure Setting' and pressing enter.
8. Select SP1, SP2, SP3, or SP4 and press enter.
9. Ensure that AF is set to 'Off'.
10. Return to the home screen by pressing the menu and power buttons at the same time (no need to hold).

### Standard Controller (CNTRLDRCPINW)

1. Turn the system OFF at the controller.
2. Press the copy button for 3 seconds, then press enter (tick) to confirm.
3. Press the up or down button to select SP: E1-E2-E2B-E3-E4-**SP**-AF-CF
4. Press the enter button to confirm.
5. Press the up or down button to select SP setting. The numbers will be shown on the display in sequence 0 - 1 - 2 - 3 - 4, select one of these numbers.
6. Press the enter button to confirm.

# Appendix 2: Error code summary

## Error display (indoor unit)

When the indoor unit encounters a recognised error, the operation lamp will flash in a corresponding series, the timer lamp may turn on or begin flashing, and an error code will be displayed.

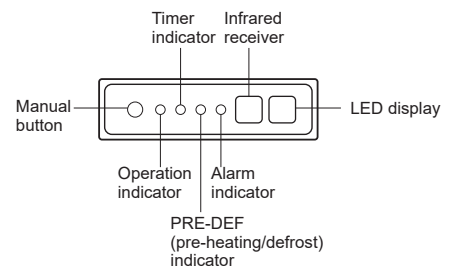

Operation lamp	Timer lamp	Display	Error information
1 time	OFF	EH00 / EH	Indoor unit EEPROM parameter error
2 times	OFF	EL01	Indoor / outdoor unit communication error
4 times	OFF	EH03	Indoor fan speed is operating outside of the normal range
6 times	OFF	EH60	Indoor room temp. sensor T1 is an open circuit or has short circuited
6 times	OFF	EH61	Evapourator coil temp. sensor T2 is in an open circuit or has short circuited
8 times	OFF	EL0C	Refrigerant leakage detection
9 times	OFF	EH0b	Communication error between indoor two chips
13 times	OFF	EH0E	Water level alarm malfunction
5 times	OFF	EC53	Outdoor room temp. sensor T4 is in an open circuit or has short circuited
5 times	OFF	EC52	Condenser coil temp. sensor T3 is in an open circuit or has short circuited
5 times	OFF	EC56	Evapourator coil outlet temp. sensor T2B is in an open circuit or has short circuited
5 times	ON	EC51	Outdoor unit EEPROM parameter error
12 times	OFF	EC07	Outdoor fan speed is operating outside of the normal range
7 times	FLASH	PC00	IPM malfunction or IGBT over-strong current protection
2 times	FLASH	PC01	Over voltage or over low voltage protection
3 times	FLASH	PC02	Top temp. protection of compressor or high temp. protection of IPM module
5 times	FLASH	PC04	Inverter compressor drive error
7 times	FLASH	PC03	High pressure protection or low pressure protection
14 times	OFF	EC0d	Outdoor unit malfunction
--	--	EHbR	Communication malfunction between external fan module and indoor unit
4 times	OFF	EH3R	External DC fan voltage is too low
4 times	OFF	EH3b	External DC fan voltage is too high
1 time	ON	--	Indoor units mode conflict with outdoor unit
--	--	EH63	Displays on wired wall controller only Communication error between wired controller and indoor unit

# Appendix 3: 18 kW indoor unit (DINLR18B1)

## Separating and reconnecting

The 18 kW indoor unit can be split into two pieces for ease of installation. The following are guidelines for splitting into two and then reconnecting.



When bringing together the two sections take care not to catch and crush the sensor line and water pump line.

1. Turn the unit upside down. Remove the electric control box cover. Disconnect the temperature sensor line and water pump line from the main control board.

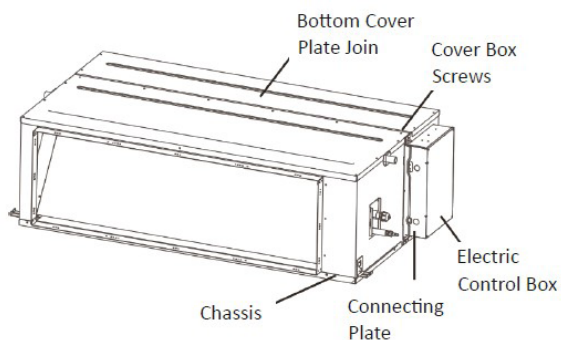

2. Remove six screws connecting the two bottom cover plates and three screws on the connecting plate of the left side panel. Remove the screws from the top cover plates and the connecting plate on the opposite side.

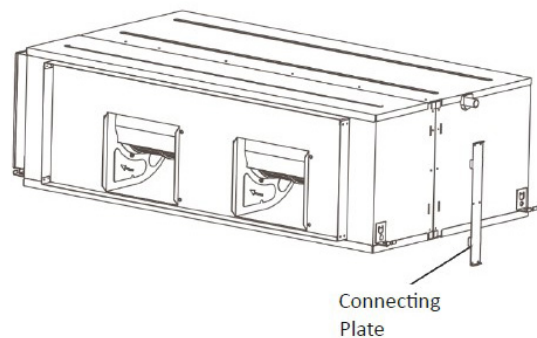

3. Separate the two sections and pull the temperature sensing cable and water pump line through the hole in the electric control box. Move the two sections to the installation position, ensure that they are facing up with the water tray on the bottom.

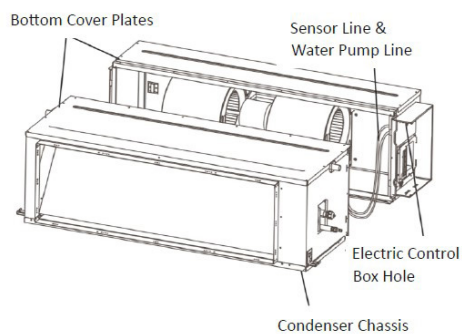

4. Connect the temperature sensing and water pump cables back to the main PC board in the electric control box.

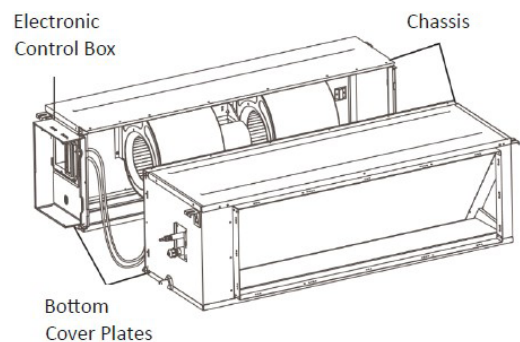

5. Reconnect the two sections, fix the top and bottom cover plates, and refix the connecting plate screws on either side.

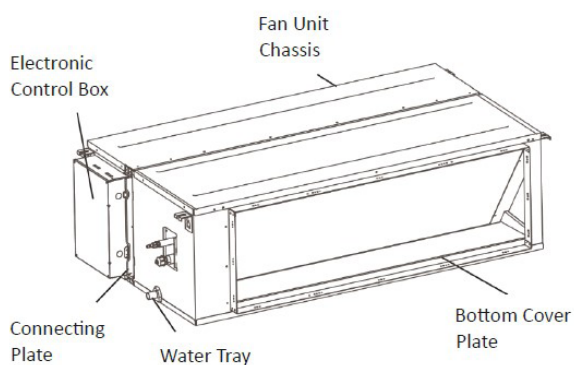

**Rinnai.co.nz**

Tel: 0800 746 624  
<http://www.youtube.com/rinnainz>  
<http://facebook.com/rinnainz>

Pro Series ducted central heating & cooling installation guide  
14097-F | 6-24