



Rinnai Heat Pump and Gas Ducted Heating Accessories catalogue

Rinnai

Important

Rinnai is constantly improving its products, and as such, information and specifications are subject to change without notice.

Warning

Improper installation, adjustment, alteration, service or maintenance can cause property damage, personal injury or loss of life.

Help is here

For more information about buying, using, and servicing of Rinnai appliances call: 0800 RINNAI (0800 746 624).

Rinnai New Zealand Limited
105 Pavilion Drive, Mangere, Auckland
PO Box 53177, Auckland Airport, Auckland 2150

Phone: (09) 257 3800
Email: info@rinnai.co.nz
Web: rinnai.co.nz
[youtube.com/rinnainz](https://www.youtube.com/rinnainz)
[facebook.com/rinnainz](https://www.facebook.com/rinnainz)

Contents

System design service.....	4
----------------------------	---

Ducted system accessories

Supply plenums	6
Return plenums	7
Y branch fittings.....	8
Y branch pre-assembled	10
Build you own	10
BTO - branch take off	12
DBTO - double branch take off.....	14
Reducer fittings.....	16
Flexible ducting - R0.6.....	17
Joiners	18

Ducted system diffusers and grilles

Supply diffusers	20
Boots - ceiling vents and diffusers.....	22

Floor / wall registers and vents

Floor / wall registers and vents.....	24
Antique floor vents.....	26
Plastic floor grilles.....	27
Boots for supply grilles and registers.....	28
Linear floor / wall bar grille - aluminium	29
Linear vents and diffusers	30
Return air grilles	31
Return air boxes	33
Return air top hats and plates	34
Return air fittings -other	35
Manual inline dampers	36
Plastic motorised dampers	37
Other.....	38

Gas ducted specific accessories and spares

Controllers	40
Flashings	41
StarPro - Accessories.....	42
StarPro - Laydown kit	44
Buffalo base boxes	45
Dampers	46

System design service

Rinnai offers a free system design service to help create the perfect climate control system for your home or office.

To get the full potential from a climate controlled system, it is important to get the system design right. Poorly designed and installed ducting can cancel out the benefits you would otherwise get from a Rinnai system.

Outlets can be positioned in the floor or ceiling and are equally effective providing the air intake point is correctly located.

The choice between ceiling or floor outlets is usually determined by the available space in and around the building for the ducting. The selection of product is also dependent on the design of the building.

An experienced system designer will custom design the duct layout to ensure an optimised central heating / cooling solution is achieved. The design team have experience in developing systems for small single dwellings through to large and complex commercial installations.

The design service will custom design your central heating / and or cooling system including recommending the ideal product(s), the location of ducts, and specifying the appropriate zones.

The system design service works closely with Rinnai's specialist dealer network and architects across the country. This is a nationwide network of qualified, trained and experienced installers recommended by Rinnai.



Email plans to ductdesign@rinnai.co.nz

Ducted system accessories



Supply plenums

Plenum boxes are used to distribute heated or cooled air throughout the building interior. They are the air's first stop after being heated or cooled and it's last stop before going back into the heat pump or furnace. After producing heated or cooled air the system must move air through the ductwork.

Each system uses two plenum boxes, a supply plenum and a return plenum.

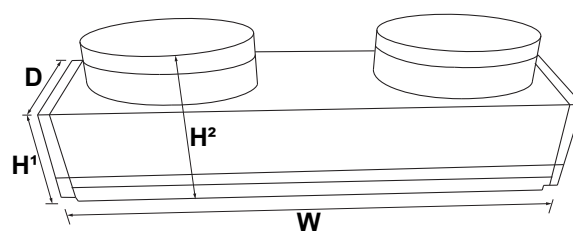

Supply plenums - R1.0 insulated panel (neck size / spigot size)			
Code	Description	Fits models	Overall dimensions H¹/H²xWxD (mm)
R4722	Supply plenum IP 136 x 706-2 x 200 mm	5 kW	180/290 x 750 x 185
R4713	Supply plenum IP 175 x 926-2 x 250 mm	7 kW	210/310 x 975 x 220
R4714	Supply plenum IP 175 x 1186-2 x 300 mm	9-10 kW	140/245 x 1195 x 380
R4715	Supply plenum IP 253 x 1000-2 x 350 mm	11-15 kW	210/295 x 1050 x 300
R4719	Supply plenum IP 385 x 1188-2 x 350 mm	18 kW	165/280 x 1230 x 330
R4725	Supply plenum IP 182 x 830-2 x 250 mm	7 kW PS2	-
R4726	Supply plenum IP 182 x 1030-2 x 300 mm	9 kW PS2	-
R4727	Supply plenum IP 235 x 1030-2 x 350 mm	11-15 kW PS2	-
R4728	Supply plenum IP 298 x 1155-2 x 350 mm	11-15 kW PS2 split	-



Return plenums

Code	Description	Fits models	Overall dimensions H ¹ /H ² xWxD (mm)
Return plenums - R1.0 insulated panel (neck size / spigot size)			
R4723	Return plenum IP 190 x 782-1 x 300 mm	5 kW	172/290 x 835 x 237
R4716	Return plenum IP 228 x 1001-2 x 300 mm	7 kW	145/245 x 1045 x 275
R4717	Return plenum IP 228 x 1261-2 x 350 mm	9-10 kW	145/245 x 1310 x 275
R4718	Return plenum IP 334 x 1145-2 x 400 mm	11-15 kW	140/245 x 1195 x 380
R4721	Return plenum IP 334 x 1145-2 x 350 mm	11-15 kW	110/220 x 1190 x 385
R4720	Return plenum IP 385 x 1188-3 x 350 mm	18 kW	130/215 x 1230 x 435
R4729	Return plenum IP 215 x 895-2 x 300 mm	7 kW PS2	-
R4730	Return plenum IP 215 x 1095-2 x 350 mm	9 kW PS2	-
R4731	Return plenum IP 270 x 1095-2 x 400 mm	11-15 kW PS2	-
Plenums - R0.6 sheet metal (neck size / spigot size)			
R4710*	Return plenum SM 228 x 1001-2 x 300 mm	7 kW	220/305 x 1020 x 250
R4712*	Return plenum SM 334 x 1145-2 x 400 mm	11-15 kW	201/305 x 1170 x 355

* Models on run out—while stocks last

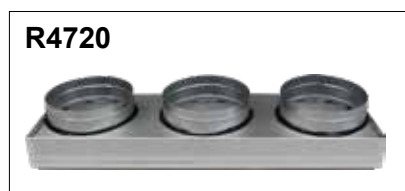

Y branch fittings

Y branch fittings allow ductwork to be split easily in two directions. Three options available:

1. Plain polyethylene, no insulation
2. Plain polyethylene, with R^M0.4 insulation
3. Metal, with R^M0.4 insulation

Polyethylene is made from UV stabilised high density polyethylene.

All product is Australian made, have positive lock duct tabs, smooth internal lines (no sharp edges), and have no joins (no air gaps).

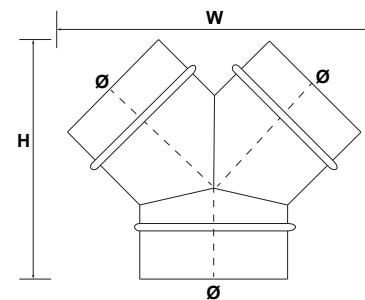

Code	Description	Overall dimensions approx. (HxW)
R4020*	Y branch Ø200 x 150 x 150 mm	330 x 400 mm
R4027*	Y branch Ø300 x 300 x 250 mm insulated metal	490 x 580 mm
R4029*	Y branch Ø300 x 300 x 300 mm insulated	480 x 485 mm
R4031*	Y branch Ø350 x 300 x 250 mm insulated	430 x 510 mm
R4033*	Y branch Ø350 x 300 x 300 mm insulated	450 x 480 mm
R4035*	Y branch Ø350 x 350 x 250 mm insulated metal	500 x 620 mm
R4037*	Y branch Ø350 x 350 x 300 mm 0.4 insulated metal	500 x 660 mm
R4039*	Y branch Ø400 x 350 x 300 mm insulated	520 x 560 mm
R4043*	Y branch Ø400 x 400 x 350 mm insulated	540 x 585 mm
R4049*	Y branch multi Ø450 x 2(450/400/350 mm) insulated	640 x 800 mm

* Models on run out—while stocks last



R4031



R4033



R4035



R4037



R4039



R4043



R4049



Y branch pre-assembled

Durable pre-assembled insulated plastic Y branch fittings with R^M1.0 insulation.



Code	Description (all pre-assembled)
R4050	Y250 / 200 / 200 insulated Y-branch with spigots
R4051	Y300 / 200 / 200 insulated Y-branch with spigots
R4052	Y300 / 250 / 250 insulated Y-branch with spigots
R4053	Y300 / 300 / 250 insulated Y-branch with spigots
R4054	Y350 / 300 / 300 insulated Y-branch with spigots
R4041	Y400 / 350 / 350 insulated Y-branch with spigots
R4055	Y450 / 350 / 350 insulated Y-branch with spigots
R4056	Y450 / 400 / 350 insulated Y-branch with spigots

Build your own

The 'build your own' modular approach gives the flexibility to customise Y-branches and BTO to suit the specific needs of a project.

Creating a custom BTO or Y-branch is simple with modular components. Follow these steps:

- 1. Select the BTO body only**
Choose the body closest in size to your required dimensions.
- 2. Add spigots or reducing spigots**
Order one spigot or reducing spigot for each of the three openings, depending on the required outlet sizes.

Kit composition

A complete BTO kit includes:

- 1 x BTO body only
- 3 x spigots, reducing spigots, or a mix of both

Ordering example

To assemble a BTO 300 x 150 x 150:

- 1 x R4107 BTO body only (300 x 250 x 200)
- 1 x R4193 300 mm spigot
- 1 x R4180 200-150 mm reducing spigot
- 1 x R4181 2- step reducing spigot (250-150 mm)



BTO body only		
Code	Description	
R4105	BTO1 body only 200 / 150 / 150 insulated	
R4106	BTO2 body only 250 / 200 / 150 insulated	
R4107	BTO3 body only 300 / 250 / 200 insulated	
R4108	BTO4 body only 350 / 300 / 250 insulated	
R4109	BTO5 body only 400 / 350 / 300 insulated	
Reducing spigots		
R4180	Reducing spigot 200-150	 <p>2-step spigot</p> 
R4181	Reducing spigot 250-150 (2-step)	
R4182	Reducing spigot 250-200	
R4183	Reducing spigot 300-200 (2-step)	
R4184	Reducing spigot 300-250	
R4185	Reducing spigot 350-250 (2-step)	
R4186	Reducing spigot 350-300	
R4187	Reducing spigot 400-300 (2-step)	
R4188	Reducing spigot 400-350	
R4189	Reducing spigot 450-400	
Spigots		
Code	Description	
R4190	Spigot 150	
R4191	Spigot 200	
R4192	Spigot 250	
R4193	Spigot 300	
R4194	Spigot 350	
R4195	Spigot 400	
R4196	Spigot 450	
Y body only		
R4480	Y body only Y200 / 150 / 150 insulated	
R4481	Y body only Y250 / 200 / 200 insulated	
R4482	Y body only Y300 / 250 / 250 insulated	
R4483	Y body only Y350 / 300 / 300 insulated	
R4484	Y body only Y400 / 350 / 350 insulated	
R4485	Y body only Y450 / 400 / 400 insulated	

BTO - branch take off

A branch take off splits a duct with the ability to create a more and less dominant flow in two directions. Three options (pictured below) are available:

1. Plain polyethylene, no insulation
2. Plain polyethylene, with R^M0.4 insulation
3. Galvanised steel, with R^M0.4 insulation

The polyethylene product is made from UV stabilised high density polyethylene.

All product is Australian made, has positive lock duct tabs, smooth internal lines (no sharp edges), and have no joints (no air gaps).

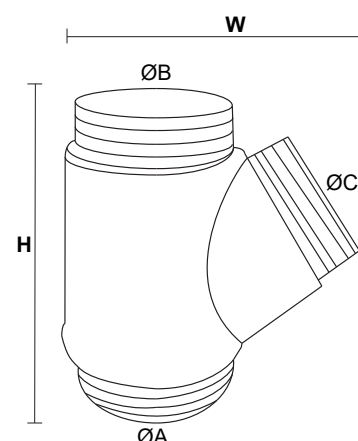

Code	Description and spigot size (A x B x C)	Approx. overall dimensions (HxW)
R4061*	BTO Ø200 x 150 x 150 mm	455 x 385 mm
R4062*	BTO Ø200 x 200 x 150 mm	530 x 410 mm
R4063*	BTO Ø200 x 200 x 200 mm	535 x 335 mm
R4064*	BTO Ø250 x 200 x 150 mm	400 x 410 mm
R4065	BTO Ø250 x 200 x 200 mm	470 x 410 mm
R4066*	BTO Ø250 x 250 x 150 mm insulated	430 x 430 mm
R4067*	BTO Ø250 x 250 x 200 mm insulated	500 x 470 mm
R4068	BTO Ø300 x 200 x 200 mm insulated	-
R4069*	BTO Ø300 x 250 x 150 mm insulated	410 x 450 mm
R4071*	BTO Ø300 x 250 x 200 mm insulated	475 x 480 mm
R4073	BTO Ø300 x 250 x 250 mm insulated	540 x 500 mm
R4077*	BTO Ø300 x 300 x 200 mm insulated	490 x 520 mm
R4079	BTO Ø300 x 300 x 250 mm insulated	580 x 545 mm
R4081*	BTO Ø350 x 300 x 150 mm insulated	500 x 550 mm
R4087*	BTO Ø350 x 350 x 150 mm insulated metal	445 x 550 mm
R4093*	BTO Ø400 x 350 x 200 mm insulated metal	505 x 595 mm
R4097*	BTO Ø400 x 350 x 350 mm insulated metal	675 x 665 mm

* Models on run out—while stocks last



Each takeoff has a stamped diameter dimension embossed on the branch



For those models not on run out, the insulation colour will be changing from black to white as new stock arrives.

DBTO - double branch take off

A double branch takeoff is designed to divide air flow in ducted systems.

The polyethylene product is made from UV stabilised high density polyethylene, with R^M0.4 insulation.

All product is Australian made, has positive lock duct tabs, smooth internal lines (no sharp edges), and have no joins (no air gaps).

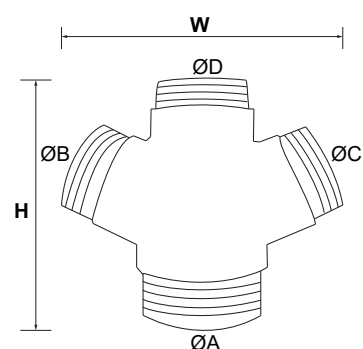

Code	Description (A x B x C x D)	Approx. overall dimensions (HxW)
R4111	DBTO insulated Ø200 x 150 x 150 x 150 assembled	-
R4112	DBTO insulated Ø250 x 150 x 150 x 150 assembled	-
R4119	DBTO insulated Ø250 x 250 x 200 x 200 assembled	455 x 645 mm
R4126	DBTO insulated Ø300 x 200 x 200 x 200 assembled	-
R4127	DBTO insulated Ø300 x 300 x 200 x 200 assembled	490 x 725 mm
R4129	DBTO insulated Ø350 x 250 x 250 x 250 assembled	520 x 730 mm
R4136	DBTO insulated Ø350 x 300 x 300 x 300 assembled	605 x 835 mm
R4110*	DBTO Ø200 x 150 x 150 x 150 assembled	460 x 590 mm
R4113*	DBTO Ø250 x 200 x 150 x 150 insulated	430 x 575 mm
R4117*	DBTO Ø250 x 250 x 150 x 150 insulated	430 x 650 mm
R4121*	DBTO Ø300 x 250 x 150 x 150 insulated	430 x 620 mm
R4125*	DBTO Ø300 x 300 x 150 x 150 insulated	445 x 665 mm
R4131*	DBTO Ø350 x 300 x 150 x 150 insulated	485 x 740 mm
R4133*	DBTO Ø350 x 300 x 200 x 200 insulated	590 x 735 mm
R4137*	DBTO Ø350 x 350 x 150 x 150 insulated	480 x 740 mm
R4141*	DBTO Ø400 x 350 x 250 x 250 insulated	665 x 795 mm
R4143*	DBTO Ø400 x 400 x 350 x 350 insulated metal	710 x 985 mm

* Models on run out—while stocks last



For those models not on run out, the insulation colour will be changing from black to white as new stock arrives.

Reducer fittings

Reducers are installed when you need to change from one duct size to another while maintaining maximum airflow through a system.

Code	Description
Metal - galvanised steel	
R4160	Reducer metal Ø200 mm to 150 mm
R4161	Reducer metal Ø250 mm to 200 mm
R4162	Reducer metal Ø300 mm to 250 mm
R4163	Reducer metal Ø350 mm to 300 mm
R4164	Reducer metal Ø400 mm to 350 mm
Poly - black plastic	
R4166*	Reducer poly Ø200 mm to 150 mm
R4167*	Reducer poly Ø400 mm to 350 mm
R4165*	Reducer poly Ø450 mm to 400 mm

* Model on run out—while stocks last



Flexible ducting

Fire rated flexible duct, designed for applications that require less rigid flexible duct. Suitable for all domestic and commercial HVAC systems.



Operating temperature: -20 °C to +80 °C
 Insulation: 50 mm thick insulation (R1.0)

Features

• Tough mylar outer jacket	• High resistance to waste permeation
• Metalised mylar inner core	• UV resistant
• Fully encapsulated spring steel wire	• Flame resistant dry lamination adhesive resin
• High and low pressure suitability	• Low resistance to airflow (correct installation)

Code	Description (length - 6 m)
R4007	Duct flex 150 mm insulated R1.0
R4008	Duct flex 200 mm insulated R1.0
R4009	Duct flex 250 mm insulated R1.0
R4010	Duct flex 300 mm insulated R1.0
R4011	Duct flex 350 mm insulated R1.0
R4012	Duct flex 400 mm insulated R1.0
R4013	Duct flex 450 mm insulated R1.0
R4005*	Duct flex 400 mm insulated R0.6
R4006*	Duct flex 450 mm insulated R0.6

* Models on run out—while stocks last



Joiners

Metal joiners (galvanised steel) are used to connect lengths of insulated duct of the same size together. The duct fits over the joiner and is taped or clamped in place.

Poly joiners are for joining two poly items such as a branch and a reducer.



Flexible duct joiners metal		
Code	Description	Height
R4170	Joiner ducting metal Ø150 mm	150 mm
R4171	Joiner ducting metal Ø200 mm	150 mm
R4172	Joiner ducting metal Ø250 mm	150 mm
R4173	Joiner ducting metal Ø300 mm	150 mm
R4174	Joiner ducting metal Ø350 mm	150 mm
R4175	Joiner ducting metal Ø400 mm	150 mm
R4176	Joiner ducting metal Ø450 mm	150 mm

Joiners polypropylene - for connecting poly fittings		
Code	Description	Approx. height
R4150*	Joiner fittings poly Ø150 mm	200 mm
R4151*	Joiner fittings poly Ø200 mm	190 mm
R4152*	Joiner fittings poly Ø250 mm	180 mm
R4154*	Joiner fittings poly Ø350 mm	195 mm

* Models on run out—while stocks last



Ducted system diffusers and grilles



Supply diffusers

A diffuser and grille distributes air exiting the climate system ductwork and provides a decorative finish over the hole holding the duct work in place.

There are different types depending on the application.

Code	Description
Core range: Supply jet diffuser - round	
Designed to not just “dump” the air straight down like standard diffusers. They disperse air over a greater area because the louvres are at staggered angles. Staggered angles give a more even distribution of air in the desired room or space.	
R4210	Downjet diffuser adjustable round 150 mm white
R4211	Downjet diffuser adjustable round 200 mm white
R4216	Downjet diffuser adjustable round 250 mm white
Core range: Supply diffuser - round (*models on run out —while stocks last)	
Quick fixing clips, resistant to scratching and fading. Manufactured from engineered polymers, and positive lock ducts.	
R4220	Diffuser round cone adjustable disk neck 150 mm white insulated
R4221*	Diffuser round cone adjustable disk neck 200 mm white
R4222*	Diffuser round cone adjustable disk neck 250 mm white insulated
R4460*	Diffuser round cone adjustable disk neck 300 mm white
Specialised range: Supply jet eyeball diffuser round (*models on run out —while stocks last)	
Ideal choice for high ceilings or walls in hotels, restaurants, shopping centres, office buildings etc.	
R4212*	Supply jet eyeball diffuser neck Ø150 mm
R4213*	Supply jet eyeball diffuser neck Ø200 mm
R4214*	Supply jet eyeball diffuser neck Ø250 mm
R4215*	Supply jet eyeball diffuser neck Ø300 mm
Core range: Supply grille square ceiling (*models on run out —while stocks last)	
Allows easy installation adaptors fit directly onto the rear of the diffusers.	
R4200*	Ceiling vent eyelash diffuser adjustable 2-way flush 255 x 255 mm - plastic
R4245*	Ceiling vent diffuser 4-way flush face 300 x 300 mm white - aluminium
R4602	Ceiling vent diffuser 4-way flush face 225 x 225 mm white - aluminium
Specialised range: Supply grille square ceiling (*model on run out —while stocks last)	
R4450*	Ceiling vent diffuser adjustable 4-way curve 300 x 300 mm

* Models on run out—while stocks last



Boots - ceiling vents and diffusers

Boots for connection to diffusers. They sit on the back of the ceiling grilles and attach to the ductwork. The boots that are angled are low profile to suit suspended ceilings or in between floors in double storey houses.

- Poly adaptor snaps-on to diffuser
- No tools or fixing required
- Positive lock duct tabs
- Complete with duct retaining clips

Code	Description
R4256*	Boot straight 300 x 300-300 mm (adapter poly plain)
R4290	Adaptor with damper 225 x 225-150 mm
R4291	Adaptor with damper 225 x 225-200 mm
R4292*	Cushion box insulated 225x225-250 R0.4
R4293*	Boot straight 300 x 300-250 mm (adapter poly plain)
R4295*	Boot 90 degrees 225 x 225-150 mm (cushion box)
R4296*	Boot 90 degrees 225 x 225-200 mm (cushion box)

* Models on run out—while stocks last



Floor / wall registers and vents



Floor / wall registers and vents

Code	Description	Neck size (mm)	Overall dimensions WxDxH (mm)
Double deflection wall diffusers - aluminium construction			
R4225WH	Wall grille metal DDL white, removable core	300 x 100	341 x 141 x 50
R4226WH	Wall grille metal DDL white, removable core	350 x 150	390 x 190 x 45
R4227WH*	Wall grille metal DDL white, removable core	400 x 200	-

Double deflection grilles are suitable for cooling, heating, and ventilation applications. Removable core makes for easy installation, cleaning, and access to dampers (if installed). Adjustable blades allow for adjustment of horizontal or vertical airflow. Aluminium construction powder coated white.



* Model on run out—while stocks last

Code	Description	Neck size (mm)	Overall dimensions WxDxH (mm)
Supply grille floor register - all steel construction			
R4232WH	Floor grille metal adjustable - white	100 x 300	344 x 140 x 40
R4232GR	Floor grille metal adjustable - grey	100 x 300	344 x 140 x 40
R4232CC	Floor grille metal adjustable - charcoal	100 x 300	344 x 140 x 40
R4232BE	Floor grille metal adjustable - beige	100 x 300	344 x 140 x 40
R4232BR	Floor grille metal adjustable - brown	100 x 300	344 x 140 x 40
R4233WH	Floor grille metal adjustable - white	150 x 350	395 x 190 x 36
R4233GR	Floor grille metal adjustable - grey	150 x 350	395 x 190 x 36
R4233CC	Floor grille metal adjustable - charcoal	150 x 350	395 x 190 x 36
R4233BE	Floor grille metal adjustable - beige	150 x 350	395 x 190 x 36
R4233BR	Floor grille metal adjustable - brown	150 x 350	395 x 190 x 36
R4234SC	Floor grille metal adjustable - satin chrome	100 x 300	344 x 140 x 40
R4235SC	Floor grille metal adjustable - satin chrome	150 x 350	395 x 190 x 36

A floor grille is a strong grille in the floor—they need to be strong enough to support considerable weight as a floor fixture. They are made of pressed metal steel construction with a powder coat finish. Control levels are recessed for a flush finish and allow for airflow adjustment.



Please note: The colours displayed online and in printed materials may not accurately represent the actual metal colours. This is especially apparent for brown, beige, antique brass, and brushed nickel. Please see your local distributor or merchant for a sample if you are unsure about the colour selection.

R4232WH

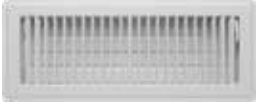

R4232GR

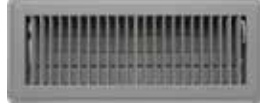

R4232CC



R4232BE



R4232BR



R4233WH

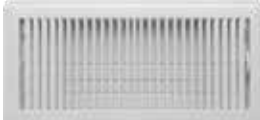

R4233GR



R4233CC



R4233BE



R4233BR



R4234SC



R4235SC



Antique floor vents

Code	Description	Neck size (mm)	Overall dimensions WxHxdepth (mm)
Antique floor vent - all steel construction			
R4240AB	Floor grille marquis antique brass	100 x 300	340 x 140 x 40
R4240PW	Floor grille marquis pewter cast iron	100 x 300	340 x 140 x 20

Heavy gauge steel construction floor vent. Designed for new modern or period homes. Hidden and recessed levers for clean lines. Rust and rattle proof damper box.

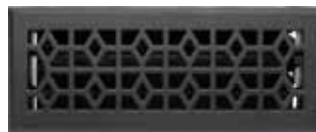

Code	Description	Neck size (mm)	Overall dimensions WxDxrim (mm)
Antique floor vent - steel face + ABS body and damper			
R4242AB	Floor grille Victorian antique brass	100 x 300	340 x 140 x 20
R4242CH*	Floor grille Victorian chrome	100 x 300	340 x 140 x 20
R4242PB*	Floor grille Victorian polished brass	100 x 300	340 x 140 x 20
R4243AB	Floor grille Victorian antique brass	100 x 300	340 x 140 x 20
R4243CH*	Floor grille Victorian chrome	100 x 300	340 x 140 x 20
R4243PB*	Floor grille Victorian polished brass	100 x 300	340 x 140 x 20

Plated steel floor vent in a Victorian design. Rust and rattle proof acrylic damper box. Hidden and recessed levers for clean lines.

* Models on run out—while stocks last

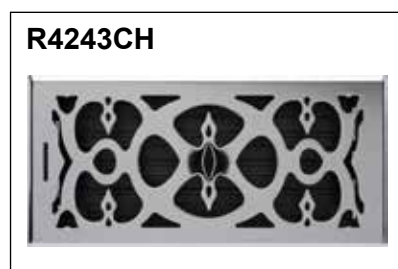

Plastic floor grilles (models on run out—while stocks last)

Manufactured from fire retardant, V-2 polycarbonate plastic, these floor grilles have been designed and built to withstand high traffic areas.

Available in two different styles and sizes. Side blow is the most popular, although, where curtains get in the way of the vent or where it is placed next to a fixture, the front blow may be the better option.

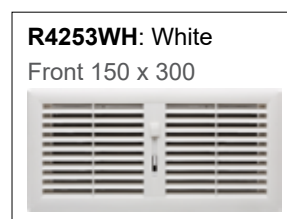
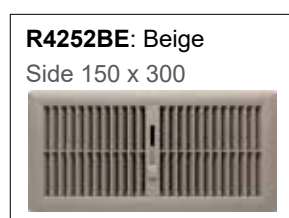
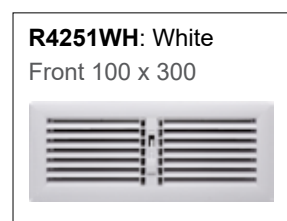

Boots for supply grilles & registers

Boots are designed to convert ductwork into a supply grille or register (vent) to heat and cool a room. All the below boots are fitted with twin butterfly dampers that stop or regulate the flow of air in zoned systems.

Code	Description
R4260*	Boot with damper 300 x 100 x 150 mm
R4270	Boot 45 degree with damper 300 x 100 x 150 mm
R4271	Boot 45 degree with damper 350 x 150 x 200 mm
R4275*	Boot 90 degree with damper 100 x 300 x 150 mm
R4276*	Boot 90 degree with damper 100 x 300 x 250 mm
R4277*	Boot 90 degree with damper 150 x 350 x 200 mm
R4280*	Boot end entry 300 x 100 x 150 mm
R4281*	Boot end entry 350 x 150 x 200 mm

* Model on run out—while stocks last



Linear floor / wall bar grilles - aluminium

Aluminium construction contemporary floor and wall vents, with anodised face to prevent rusting. Adjustable variants have a fully adjustable damper to regulate air flow. Lever can be removed if preferred.

Code	Description	Neck size (mm)	Face size approx. (mm)
Linear floor or wall bar grille - full aluminium construction			
R4238AL	Linear bar adjustable, fixed core anodised aluminium	300 x 100	140 x 340 (20 rim)
R4238BE*	Linear bar adjustable, fixed core beige	300 x 100	140 x 340 (20 rim)
R4238GM	Linear bar adjustable, fixed core gunmetal	300 x 100	140 x 340 (20 rim)
R4239AL*	Linear bar adjustable, fixed core anodised aluminium	350 x 150	190 x 390 (20 rim)
R4239BE*	Linear bar adjustable, fixed core beige	350 x 150	190 x 390 (20 rim)
R4239GM	Linear bar adjustable, fixed core gunmetal	350 x 150	190 x 390 (20 rim)

* Model on run out—while stocks last

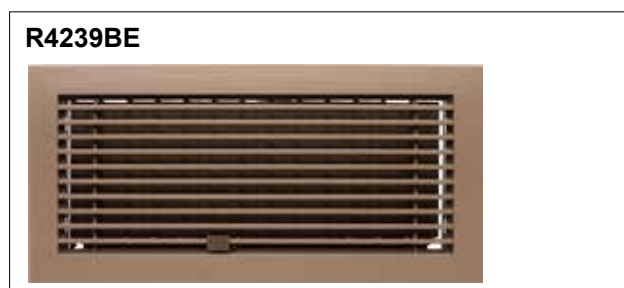
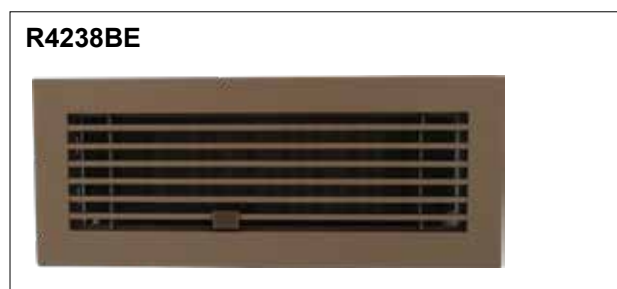
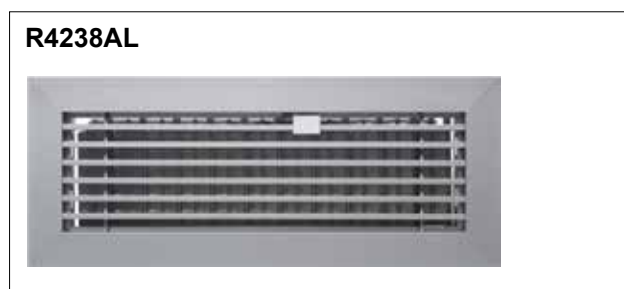

Linear vents and diffusers

Code	Description
Boots: Linear vents and diffusers	
R4294*	Adapter grille insulated 200 - 890 x 80
R4470*	Linear diffuser fixed core 2-slot white 890 x 80
R4610*	Bar grille removable core 590 x 140
R4611*	Bar grille removable core 890 x 140
R4630*	Linear slot diffuser 590 x 137
R4631*	Linear slot diffuser 890 x 137
R4633	Linear slot diffuser 2-slot white 25 mm 600
R4650	Boot grille / diff 600 x 150-150 mm
R4651*	Boot grille / diff 900 x 150-200 mm



* Model on run out—while stocks last

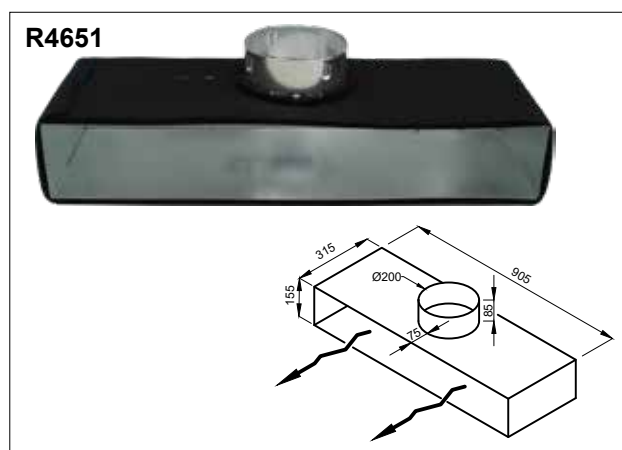
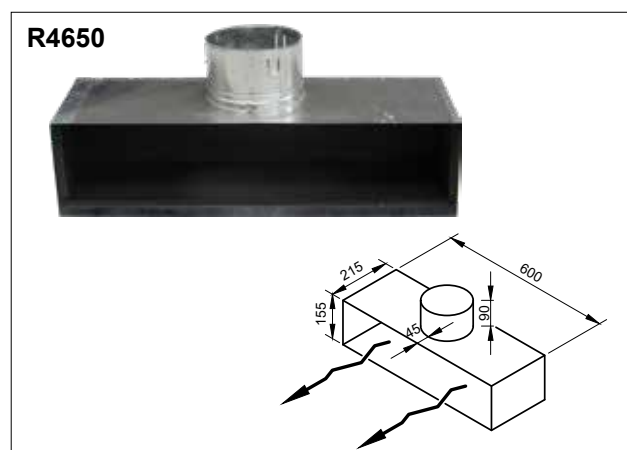
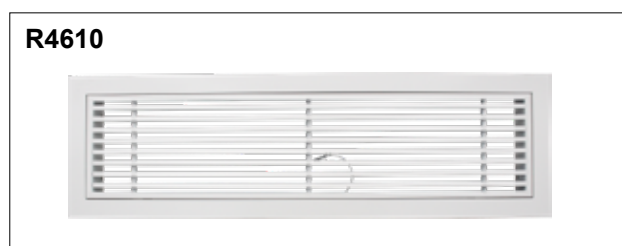

Return air grilles

A return air grille allows air to return to any cooling or heating system. It typically has an air filter attached to improve air quality in the home and stop contaminants (dust, pet hair, pollen etc) from entering into the HVAC system.

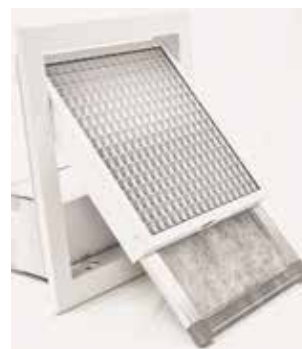

Code	Description	Neck size
R4422*	Door relief grille 440 x 290 mm white	-
R4429*	Door relief grille 590 x 44 mm	-
R4341WH	RAG egg crate hinged with filter white	390 x 590 mm
R4342WH	RAG egg crate hinged with filter white	390 x 740 mm
R4343WH	RAG egg crate hinged with filter white	390 x 890 mm
R4351WH*	Linear bar RAG hinged with filter white	390 x 590 mm
R4353WH*	Linear bar RAG hinged with filter white	390 x 890 mm
R4359WH*	RAG no filter plastic white	390 x 560 mm
R4360BE*	RAG heavy duty floor beige	390 x 590 mm
R4362BE*	RAG heavy duty floor beige	390 x 890 mm

* Model on run out—while stocks last

R4422: Door relief grille



Representation of door relief grille side profile

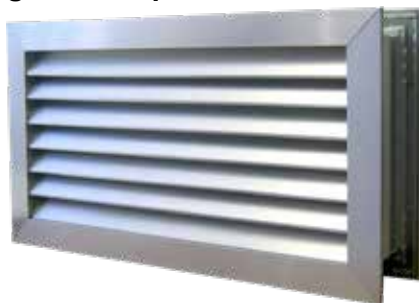

**RAG egg crate hinged with filter white - three sizes
R4341WH, R4342WH, R4343WH**

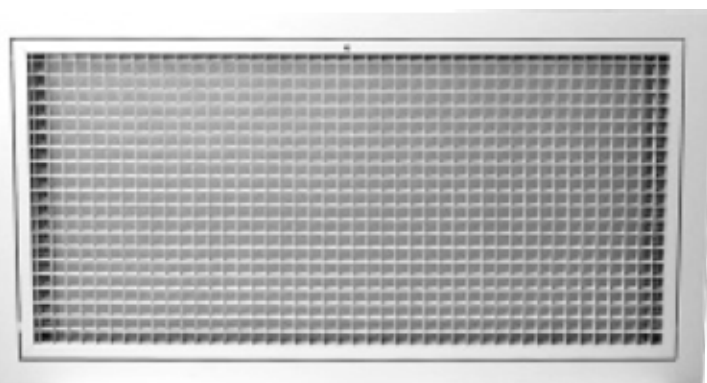

Return air grilles continued

Linear bar return air grille hinged with filter white - two sizes
R4351WH, R4333WH



Return air grille no filter, plastic, white
R4359WH

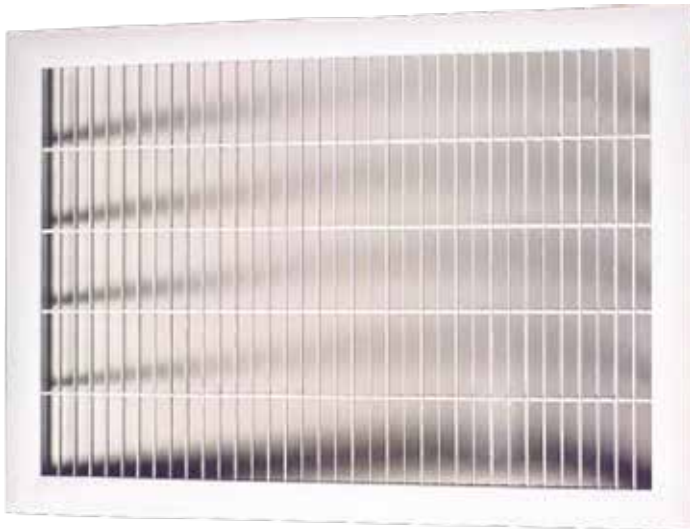

Return air grille heavy duty floor beige - two sizes
R4360BE, R4361BE

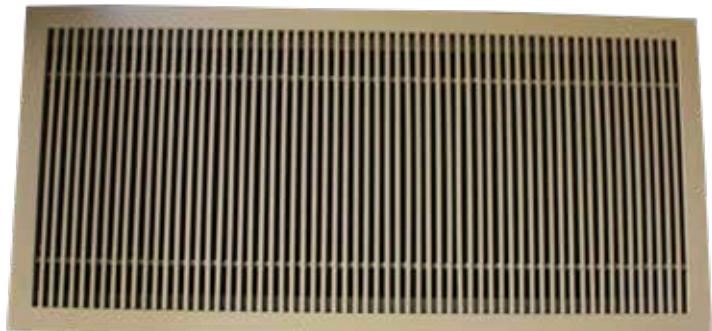
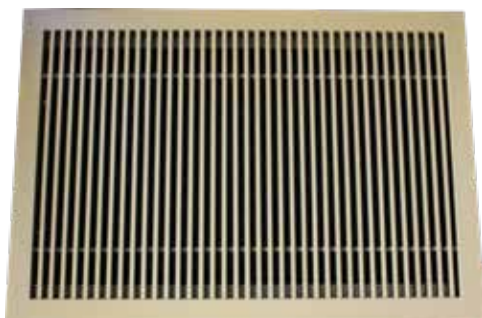

Return air boxes

The return air box is a plenum that attaches a return duct to a return grille in the wall or ceiling.

Code	Description	Spigot size	Overall dimensions (mm)
R4332	Return air box 590 x 390	Ø300 mm	H-598, W-398
R4333	Return air box 590 x 390	Ø350 mm	H-598, W-398
R4334	Return air box 740 x 390	Ø350 mm	H-747, W-398
R4335	Return air box 740 x 390	Ø400 mm	H-747, W-398
R4336	Return air box 890 x 390	Ø350 mm	H-900, W-403
R4337	Return air box 890 x 390	Ø400 mm	H-900, W-403
R4700	Return air box insulated 740 x 390 mm	2 x Ø300 mm	H ¹ -220, H ² -310, D-420, W-800
R4701	Return air box insulated 890 x 390mm	2 x Ø350 mm	H ¹ -220, H ² -310, D-420, W-930
R4702	Return air box insulated 890 x 390mm	2 x Ø400 mm	H ¹ -220, H ² -310, D-420, W-930



Return air top hats and plates

The return air box is a plenum that attaches a return duct to a return grille in the wall or ceiling.

Code	Description
R4371	Return air top hat 300 mm
R4372	Return air top hat 350 mm
R4373	Return air top hat 400 mm
R4374	Return air top hat 450 mm
R4375	Return air plate spigot 500x500-300 mm
R4376	Return air plate spigot 500x500-350 mm
R4377	Return air plate spigot 500x500-400 mm
R4378	Return air plate spigot 600x600-450 mm



Return air fittings - other

Code	Description
R4315	Filter replacement kit 780 x 430 mm
R4320*	Return air box 560 x 380 x 300 mm
R4329*	Return air flange adjustable 390 x 590-740 mm
R4330	Return air flange 390 x 890 mm

* Model on run out—while stocks last

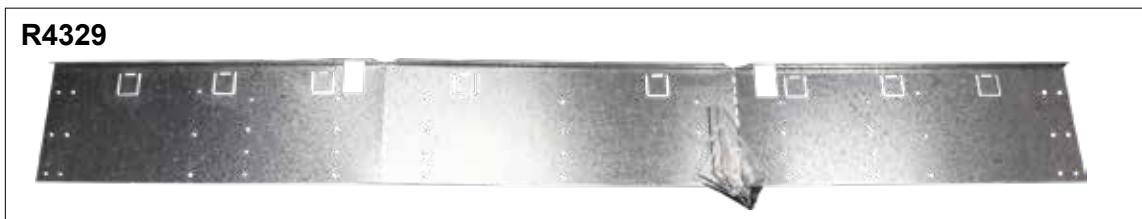
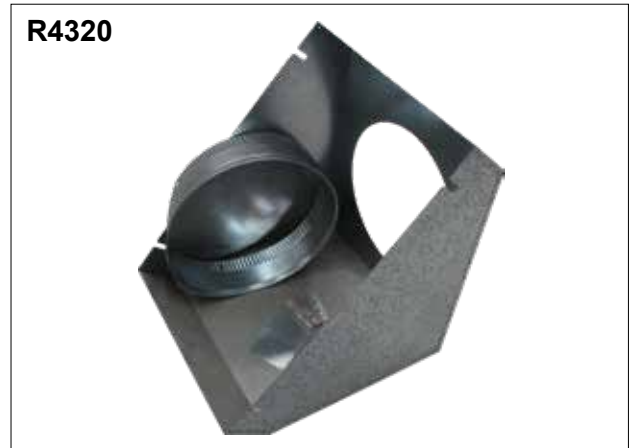

Return air flange made up

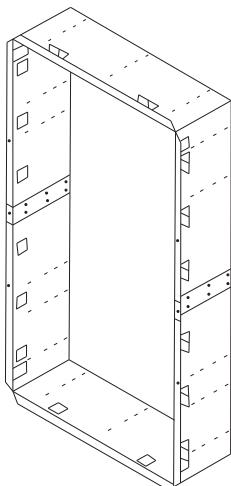

Manual inline dampers

Device used to control the airflow within heating, ventilation, and air conditioning (HVAC) systems.



- **Function**
Dampers regulate the volume of air passing through a duct. They can be used to balance airflow between different zones in a building, ensuring comfort and efficiency.
- **Manual operation**
Unlike automatic dampers, which are controlled by a thermostat or building management system, manual dampers require a person to adjust them. This is usually done using a lever or a knob connected to the damper.
- **Inline placement**
'Inline' refers to the damper being installed within the ductwork, as opposed to at an outlet or intake. This allows for precise control of airflow within the duct system.
- **Applications**
Commonly used in residential and commercial HVAC systems to balance air distribution, shut off air to unoccupied areas, or fine-tune system performance.
- **Installation**
Involves cutting into the ductwork and securing the damper inside the duct. The adjustment mechanism remains accessible from the outside of the duct.

Code	Description
R4410	Manual inline damper Ø150 mm
R4411	Manual inline damper Ø200 mm
R4412	Manual inline damper Ø250 mm
R4413	Manual inline damper Ø300 mm
R4414	Manual inline damper Ø350 mm
R4415	Manual inline damper Ø400 mm

Plastic motorised dampers

Device used to control the airflow within heating, ventilation, and air conditioning (HVAC) systems. They offer remote and automatic control, which is useful in buildings where HVAC systems are installed high up or require precise zone control.



Specification summary

Power supply	24 V AC \pm 15%, 50 Hz
Connection	RJ12 socket and plug
Output	1 RPM, 0.2.5 Nm
Current draw	\leq 210 MA
Power consumption	\leq 5 W
Drive open / close time	15 secs / 15 secs
Noise (SPL @0.3 m)	<45 dB
Ambient temperature	-10 to +65 °C
Ambient RH	<85%
Weight	0.37 kg
Degree of protection	IP21
Electrical insulation class	III (SELV)

Code	Description
R4501	Plastic motor damper Ø150 24 V plug in c/w 12 m lead
R4502	Plastic motor damper Ø200 24 V plug in c/w 12 m lead
R4503	Plastic motor damper Ø250 24 V plug in c/w 12 m lead
R4504	Plastic motor damper Ø300 24 V plug in c/w 12 m lead
R4505	Plastic motor damper Ø350 24 V plug in c/w 12 m lead
R4506	Plastic motor damper Ø400 24 V plug in c/w 12 m lead

Other

Copper pair coil 20 m

- R4310: 6.35 x 9.53 mm ($\frac{1}{4}$ - $\frac{3}{8}$)
- R4311: 6.35 x 12.70 mm ($\frac{1}{4}$ - $\frac{1}{2}$)
- R4312: 9.53 x 15.90 mm ($\frac{3}{8}$ - $\frac{5}{8}$)
- R4316: 9.53 x 19.10 mm ($\frac{3}{8}$ - $\frac{3}{4}$)
- R4317: 6.35 x 15.90 mm ($\frac{1}{4}$ - $\frac{5}{8}$)

Pre-insulated copper coil. Easy to shape and bend. Can be used in tight spaces without insulation being ripped or damaged. 20 m coils eliminates the need to seal joints every two metres.



R4314

Mounting feet PVC 420 mm

Plastic mounting feet with horizontal grooves that allow fixing in any position. Comes with screw packs to allow the feet to be secured to the ground. Maximum weight 140 kg.



R4390

Strap hanging 25 mm x 50 mm roll

Polypropylene woven strap designed for hanging flexible ducting. Durable, lightweight, and easier to install than metal strapping. Readily moulds to the shape of the ducting, and can be easily cut.

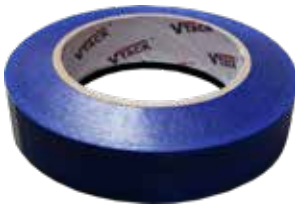

R4395

Tape duct grey 48 x 30 m

Vinyl tape with high adhesive strength. Can be stretched easily without breaking. Suitable for air conditioning duct joining and sealing. Flame retardant.



R4456

90 degree bend 400 mm insulated

Duct fitting that changes the direction of airflow by 90 degrees, allowing for turns in the ductwork.



R4457

90 degree bend 450 mm insulated

Duct fitting that changes the direction of airflow by 90 degrees, allowing for turns in the ductwork.



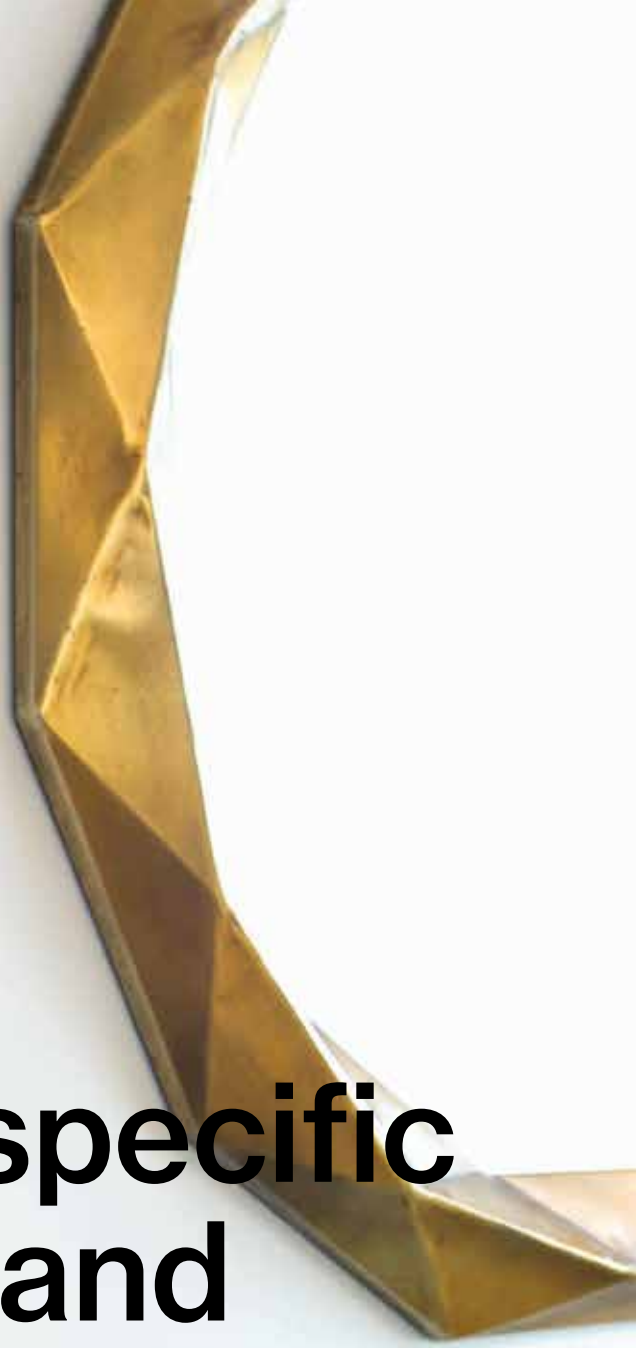

Gas ducted specific accessories and spares



Controllers

Code	Description
B015136	ACC Network 506 module 240 V
B017530	Elect control interface 519 assembly
B018855	Elect control interface 529 assembly
B022880	ACC thermostat digital CTB
B023178	ACC network 516 module low voltage
B024892	ACC power module NPM-1
B061006	ACC zoneplus 4-zone control pack
B062214	539 interface BX3/2PWN/CC3
B063283	ACC add on relay pack
CNTRLHTRPROGE	Rinnai programmable thermostat
B022890	Rinnai Networker NC6
B024891	Rinnai Zoneplus remote temperature sensor
B063047	Rinnai Touch NC7 controller
R4500	Rinnai Touch Wifi controller kit



B022880

Digital room thermostat, an easy to operate manual thermostat. Requires 2 x AA batteries.

On/Off, backlight, and temperature adjustment. Temperature set-point range 5-35 °C.

IP30.

Recommended for CC3 / BX3.



B024892



B061006



ZonePlus works in unison with any Rinnai SP series ducted gas heater with 5 or 6 star efficiencies.

Pack includes controller and 3 sensors.???

B062214



B063283



The relay pack acts as an intermediary, allowing different parts of the system to communicate and work together efficiently.

CNTRLHTRPROGE



The Programmable Controller can operate in either auto or manual modes. To program you simply preset temperatures and times for the heating/cooling system to turn on and off. This Controller is also suitable for Brivis ICE™ system with the Classic Heater Range.

R022890



B024891



B063047



Recommended for BX5, SP5, and SP6.

R4500



Must also have the NC7 or NC6 controller. Recommended for BX5, SP5, SP6. Kit contains module, 20 m cable, screw pack and instructions.

Flashings

Flashings are components used in HVAC installations, specifically for ducted heating and cooling systems. They are designed to seal and protect areas where ducts or pipes pass through walls, roofs, or other structures.

Flashings help prevent water, dust, and debris from entering the building through these openings, ensuring the system operates efficiently and reducing the risk of damage or leaks.



Code	Description
B019001	Flashing 150B15/20 standard
B019002	Flashing buff 15/20/20XA 200 mm
B019003	Flashing buff 15/20/20XA 250 mm
B019004	Flashing buff 15/20/20XA 300 mm
B019005	Flashing buff 15/20/20XA 350 mm
B019006	Flashing buff 15/20/20XA 400 mm
B019007	Flashing 150 B26 standard
B019008	Flashing buff 26/26XA 200 mm
B019009	Flashing buff 26/26XA 250 mm
B019010	Flashing buff 26/26XA 300 mm
B019011	Flashing buff 26/26XA 350 mm
B019012	Flashing buff 26/26XA 400 mm
B021955	ACC flashing 75 mm S/Pro 21/23 standard
B021956	ACC flashing 75 mm S/Pro 30 standard
B021972	Flashing 150 mm S/Pro 30
B021973	Flashing 200 mm S/Pro 30
B021974	Flashing 250 mm S/Pro 30
B021975	Flashing 300 mm S/Pro 30
B021976	Flashing 350 mm S/Pro 30
B021977	Flashing 150 mm S/Pro 21/23
B021978	Flashing 200 mm S/Pro 21/23
B021979	Flashing 250 mm S/Pro 21/23
B021980	Flashing 300 mm S/Pro 21/23
B021981	Flashing 350 mm S/Pro 21/23

StarPro Series - Accessories

Code	Description
B009040	Union body 3/4 inch male
B021385	External Flue terminal assembly XXeXX
B061775	ACC conversion kit NG-LPG SP623
BO61776	ACC conversion kit NG-LPG SP630
B061777	ACC conversion kit NG-LPG SP635
B063244	Flue kit remote internal stainless steel
B063279	ACC conversion kit LPG-NG SP23 35
B063280	ACC conversion kit LPG-NG SP30
R4379	Plate adapter 350 x 300 SP623 kit

B009040



B021385



- Waterproof flue terminal
- Neck size 60 mm
- Push fit
- YouTube video <https://www.youtube.com/watch?v=Uqhg8pVbU6I>

B061775



B063279



R4379



The adaptor plate kit consists of two plates (supply air and return air). Designed for use when installing a SP6231U externally, where the existing ducting is 300 mm and there is not enough room to fit reducers to the 350 mm connections supplied with the furnace.

StarPro Series - Laydown kit

The laydown kits allow suitable systems to be installed horizontally, which is common for installations in tight spaces such as crawl spaces, basements, or ceiling spaces.

Internal installations only.

Kits contain:

- Three pre-assembled galvanised legs
- Self tapping screws
- Installation instructions



Code	Description
B023208	Kit laydown StarPro 15/21/23
B023263	Kit laydown StarPro 30/35 internal
B064526	ACC kit laydown SP5/6U 15~35

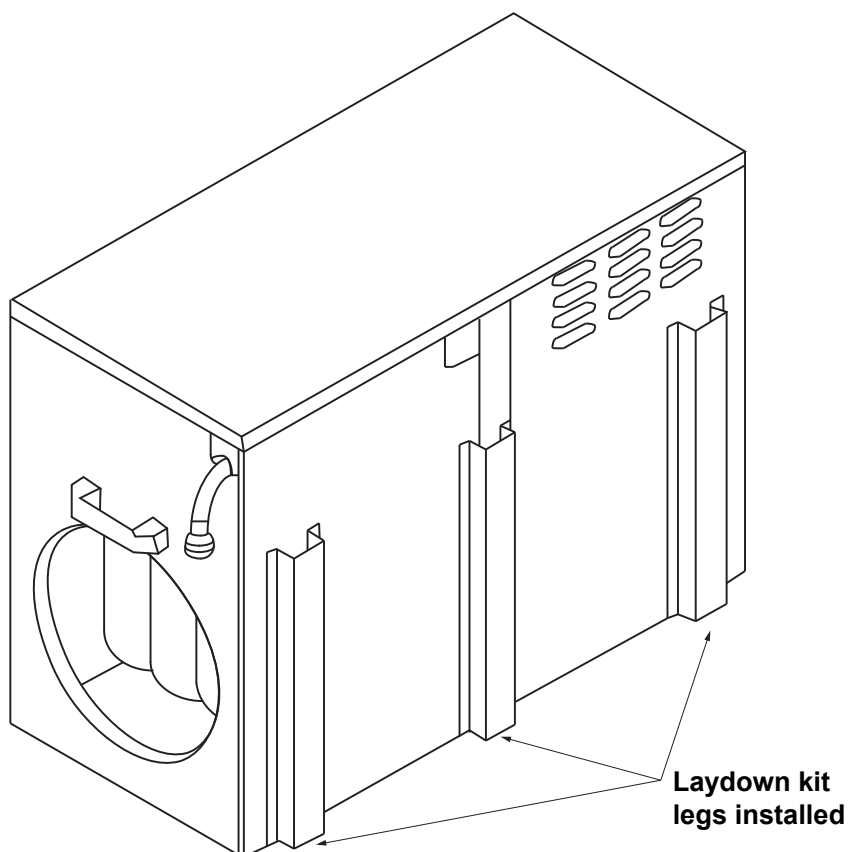

Buffalo base boxes

A base box serves several functions:

- **Stability and support:** It provides a stable and secure platform for mounting the heater ensuring it remains upright and steady during operation.
- **Elevation:** It elevates the heater above ground level, protecting it from potential damage caused by water, debris, and other factors that may be present at ground level.
- **Airflow:** By raising the heater, the base box helps ensure adequate airflow around the unit, which is essential for efficient operation and proper ventilation.
- **Ease of installation:** The base box often includes provisions for easier connections to ductwork and gas lines, simplifying the installation process.
- **Protection:** It can offer additional protection to the unit's components from the elements, extending the lifespan of the heater.



Base box comes assembled.

Code	Description
B010466	Base box assembly 12/20 std
B010576	Base box assembly 14/26 std
B012131	Base box 350 mm Buffalo 14/20XA
B012134	Base box 400 mm Buffalo 26XA

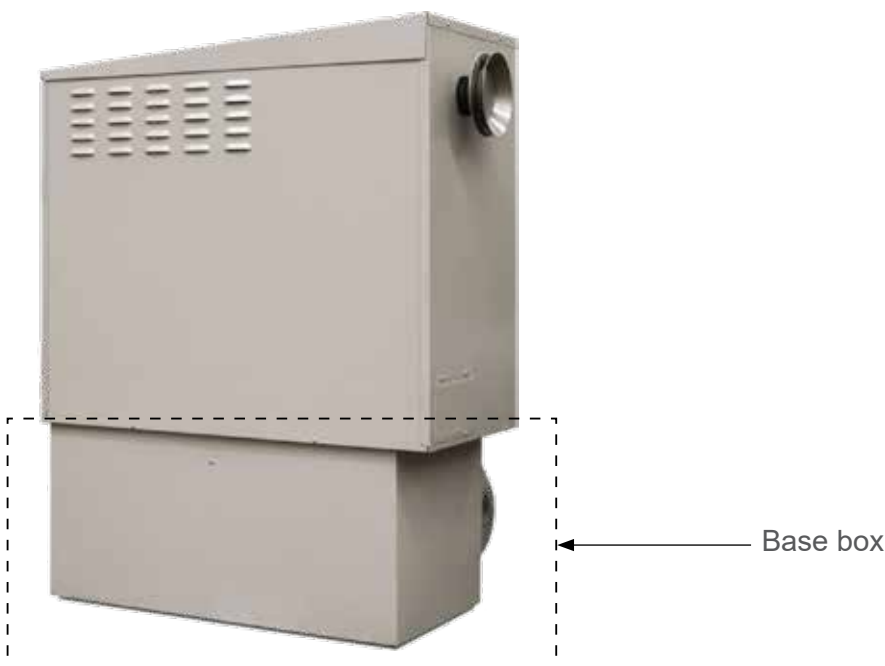

Dampers

A gas ducted heating damper is a device used in ducted heating systems to control the flow of heated air through the ductwork. Here's what it does:

Regulate Airflow: The primary function of a damper is to regulate the amount of heated air that flows into different areas or zones of a building. By adjusting the position of the damper, you can control how much air is delivered to specific rooms.

Zone Control: In zoned heating systems, dampers are used to create different heating zones within a building. Each zone can be controlled independently, allowing for customized temperature settings in different areas. This improves comfort and can lead to energy savings by heating only the areas that need it.

Balance System Pressure: Dampers help balance the pressure within the duct system. Proper balancing ensures that the heating system operates efficiently and reduces wear and tear on the system components.

Shut Off Airflow: Dampers can completely shut off airflow to certain areas when heating is not needed, which can be useful in unused or rarely used rooms, further enhancing energy efficiency.

Improve System Efficiency: By controlling and optimizing airflow, dampers help the heating system run more efficiently, reducing energy consumption and potentially lowering heating costs.

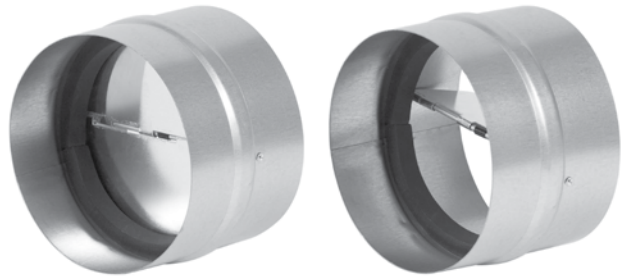

Code	Description
R4385*	Backflow damper 150 mm
R4386*	Backflow damper 200 mm
R4387*	Backflow damper 250 mm
R4388*	Backflow damper 300 mm
R4400*	Zone damper 150 mm 24 V Belimo
R4401*	Zone damper 200 mm 24 V Belimo
R4402*	Zone damper 250 mm 24 V Belimo
R4403*	Zone damper 300 mm 24 V Belimo
R4404*	Zone damper 350 mm 24 V Belimo
R4405*	Zone damper 400 mm 24 V Belimo

R4385



R4402



* Model on run out—while stocks last

Example of how a zone damper is connected



Rinnai.co.nz

Tel: 0800 746 624

<http://www.youtube.com/rinnainz>

<http://facebook.com/rinnainz>